



Step 3: Remove old mouth lever (2mm allen wrench).

Step 4: If not already done, repair, clean, and lubricate head assembly.

Step 5: Install new neck-cover, PART 1: Using E-6000 adhesive, glue the small strips of Velcro to sides of the head frame.



Step 6: Take the new mask and align it so that the eyes are centered in the eyesockets and the eyelids open and close without rubbing the mask. Then lift up the fur flap between the eyesockets of the mask. Using the (pencil or pen) mark the screw hole on the head frame.

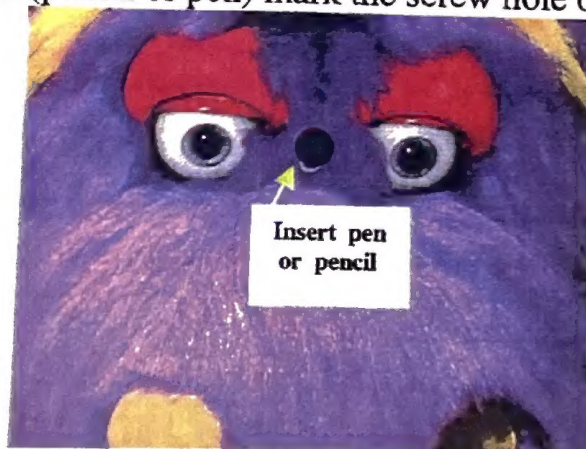

Step 7: With center punch and hammer mark hole for drilling.

Step 8: Using 7/32 drill bit, drill the marked hole.

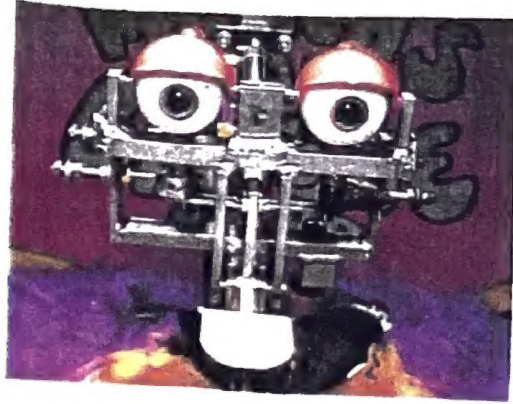

Step 9: On the back of the head-frame, there is the T-frame for the mouth cylinder. From the bottom of the top of the "T" measure down 3/4"

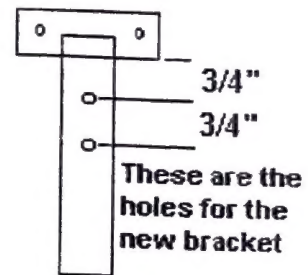
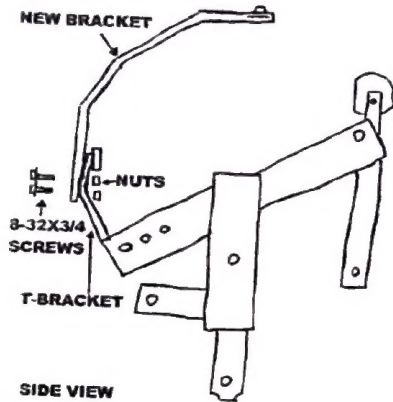

This is the T-frame for the mouth cylinder

and in the center of the frame mark for a hole, then 3/4" lower mark for another hole in the center of the frame.

Step 10: Using center punch and hammer mark holes for drilling.

Step 11: Using a 3/16" drill bit, drill the marked holes. Insert the 10-24 X 1 1/4" screws with the heads and washers on the outside of the frame and the nylock nut on the inside of the frame.

Step 12: Installing mouth lever and jaw: Loosen the two screws under the tongue and remove jaw from mouth lever. Align mouth lever with hole in frame and insert mouth lever pin. (do not forget the spacer washers.) Then tighten the 2mm set screws with the allen wrench. Then slip the top of the mouth lever into mouth cylinder clevis and insert fast pin w/load washer. Reinstall jaw to mouth lever, (leaving screws slightly loose).



- Step 13: Installing new neck cover, PART 2: Check to see if the E-6000 is set on the small Velcro strip, on the sides of the head frame. If not come back to this step when it is. If so then take the neck cover, with the open side toward the back, and push the bottom part under the body-shell and around the neck. Lineup the Velcro strips on the inside of the neck cover to the ones on the head frame, and attach. Then Velcro the back of the neck cover.
- Step 14: Installing the mask: Slip the new head frame bracket under the head and washer of the screw on the back of head frame. Then snug screws to frame, but not tight. Then insert 10-24 X 1" screw w/washer into hole in mask between eyesocktes, align the mask so that the 10-24 X 1" screw will screw into the barrel nut, then screw it in. Now snap the 3 snaps of the new head frame bracket to the snaps inside the new mask. Then align mask properly and tighten the two screws on the back of the head frame

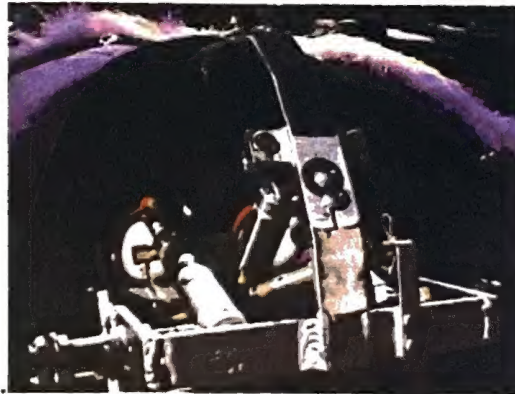

- Step 15: Install the back of the head by slipping the back head shell into the back of the mask, pressing slightly to make sure the Velcro sticks properly. Next pull the fur around the back of the head and snap it into place.



Step 16: Checking the mouth movement manually: Manually move the jaw up and down, checking for center alignment, rubbing, closing to much or not enough. Adjust properly then tighten screws under the tongue, then Velcro tongue back.

Step 17: Checking movement with the computer: The reason for this is as usual to check the movements for proper speed, or rough movement, and to check the lengths of the range of motion. First air up the charter, then power up the computer.

A. On the LCD display push the "enter" button twice. It will show.

DIAGNOSTICS

VCR ADJUST

B. Then push the "down" button once. It will show.

DIAGNOSTICS

MUNCH

C. Next push the "enter" button twice. It will show.

MUNCH (on/off flashing)

MOUTH

This will start the mouth movement. To stop the movement, just push the "enter" button once. Make the proper adjustments, and repeat this step as many times as needed.

Step 18: Check the rest of the head movements, using the same procedure as above or a Diagnostics tape. After checking and properly adjusting everything, finish putting Munch back together again. Clean and brush Munch.

Step 19: Double check make sure you didn't forget anything like the neck cover or anything else.

Step 20: Pick up and clean area.

Step 21: Start show.

Step 22: Have a Great CEC Day!!

If you have any question call Robert at (972) 258-5557.

04/20/00

MUNCH MASK KIT LIST

1. FACE MASK



2. BACK HEAD SHELL



3. NECK COVER



4. JAW



5. MASK FRAME



6. FRAME HARDWARE

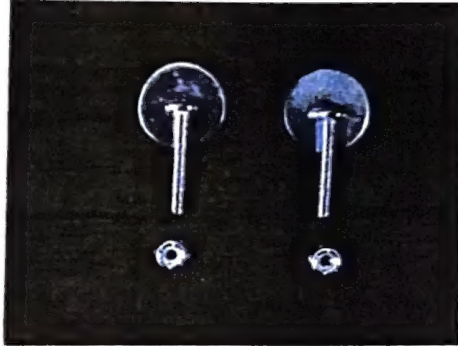

7. MASK HARDWARE

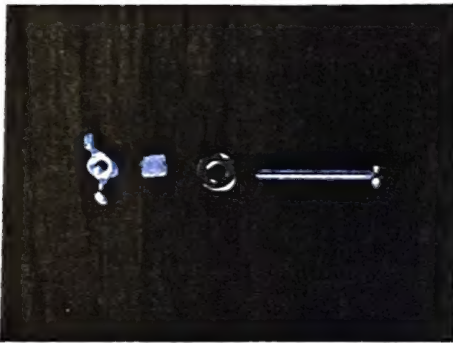

8. MOUTH LEVER

