



This is a digital copy of a book that was preserved for generations on library shelves before it was carefully scanned by Google as part of a project to make the world's books discoverable online.

It has survived long enough for the copyright to expire and the book to enter the public domain. A public domain book is one that was never subject to copyright or whose legal copyright term has expired. Whether a book is in the public domain may vary country to country. Public domain books are our gateways to the past, representing a wealth of history, culture and knowledge that's often difficult to discover.

Marks, notations and other marginalia present in the original volume will appear in this file - a reminder of this book's long journey from the publisher to a library and finally to you.

Usage guidelines

Google is proud to partner with libraries to digitize public domain materials and make them widely accessible. Public domain books belong to the public and we are merely their custodians. Nevertheless, this work is expensive, so in order to keep providing this resource, we have taken steps to prevent abuse by commercial parties, including placing technical restrictions on automated querying.

We also ask that you:

- + *Make non-commercial use of the files* We designed Google Book Search for use by individuals, and we request that you use these files for personal, non-commercial purposes.
- + *Refrain from automated querying* Do not send automated queries of any sort to Google's system: If you are conducting research on machine translation, optical character recognition or other areas where access to a large amount of text is helpful, please contact us. We encourage the use of public domain materials for these purposes and may be able to help.
- + *Maintain attribution* The Google "watermark" you see on each file is essential for informing people about this project and helping them find additional materials through Google Book Search. Please do not remove it.
- + *Keep it legal* Whatever your use, remember that you are responsible for ensuring that what you are doing is legal. Do not assume that just because we believe a book is in the public domain for users in the United States, that the work is also in the public domain for users in other countries. Whether a book is still in copyright varies from country to country, and we can't offer guidance on whether any specific use of any specific book is allowed. Please do not assume that a book's appearance in Google Book Search means it can be used in any manner anywhere in the world. Copyright infringement liability can be quite severe.

About Google Book Search

Google's mission is to organize the world's information and to make it universally accessible and useful. Google Book Search helps readers discover the world's books while helping authors and publishers reach new audiences. You can search through the full text of this book on the web at <http://books.google.com/>

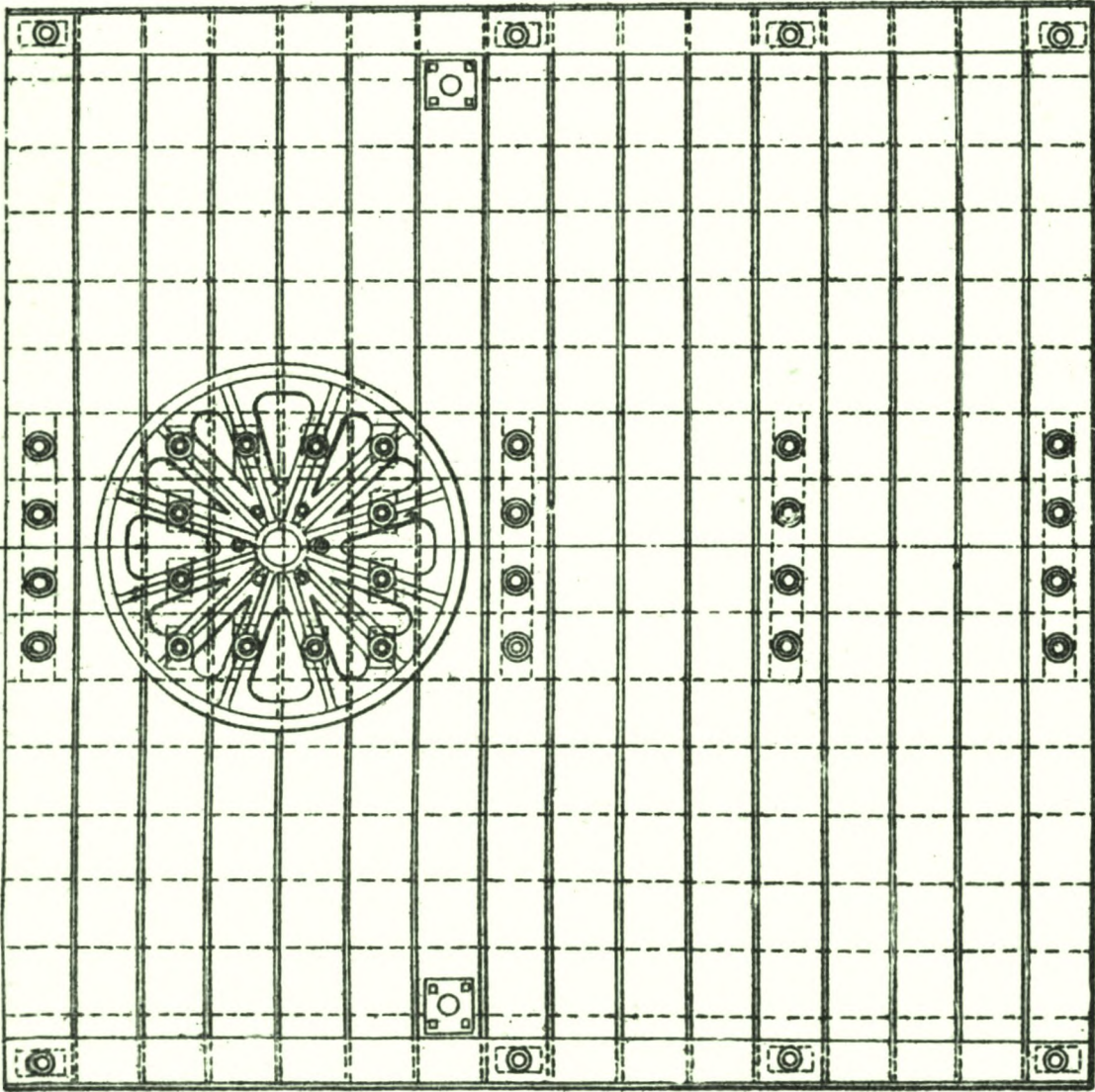

*Handbook of the 4-inch gun,
marks V and VI. (Land service.)*

Great Britain. War Office

3-d

UF
565
.G7
4 in. B.L.
(5-6)

6th Ed. 1904

[All Rights Reserved.]

40185
9669

HANDBOOK

OF THE

4-INCH B.L. GUN, MARKS V AND VI.

(LAND SERVICE.)

1904.

Exchange Duplicate, L. C.



LONDON:
PRINTED FOR HIS MAJESTY'S STATIONERY OFFICE,
BY HARRISON AND SONS, ST. MARTIN'S LANE,
PRINTERS IN ORDINARY TO HIS MAJESTY.

And to be purchased, either directly or through any Bookseller, from
EYRE & SPOTTISWOODE, EAST HARDING STREET, FLEET STREET, E.C.4,
or OLIVER & BOYD, EDINBURGH;
or E. PONSONBY, 116, GRAFTON STREET, DUBLIN.

Price One Shilling.

21 F
565
.G7
4 in. B.L.
(5-6)

CONTENTS.

	PAGE
Guns	3
Breech and Firing Mechanisms	4
Removing and Replacing Breech Mechanism.. .. .	8
Appurtenances, &c. {	9
	9
	10
	10
	11
Care and Preservation of Gun and Fittings, &c.	11
Rifle, Aiming	12
Carriage, Travelling	13
Limber	15
Carriage, Garrison, Vavasseur	13 and 16
Slide	13 and 17
Care and Preservation of {	18
20	
Electrical Firing Gear for Vavasseur Garrison Carriages	20
Platforms, Double-decked	21
Plate, Pivot	22
Arm, Radial	22
Plate, Wheel, Platform Siege	22
Plank, Trail, Siege	23
Notes on Laying Platform, D.D., and Checking Recoil	24
Cartridges.	25
Projectiles	27
Bags, burster	29
Augmenting strips	29
Extractor, Drill Shell	30
Fuzes	30
Tubes	34
Notes Regarding Tubes	37
Range Table	38
Drill	41
Instructions for Using the Large Clinometer.. .. .	49

DIAGRAMS OF PACKING.

Carriage, Limber, and Limber and Store Boxes	51
--	----

PLATES.

Gun	I and II
Breech and Firing Mechanisms	III and IV
Sight Bracket	V
Box, Obturating Pads and Discs	VI
Extractors, Tube P.	VII
Rifle, aiming	VIII
Carriage, Travelling	IX
Limber	X
Carriages and Slides, Garrison, Vavasseur, Marks I and II	XI and XII
Platform, Double-decked, Marks I and II	XIII and XIV
Cartridges	XV and XVI
Projectiles	XVII to XX
Fuzes	XXI to XXIII
Tubes	XXIV to XXVII

Exch.
Original

HANDBOOK

OF THE

4-INCH B. L. GUNS.

(LAND SERVICE.)

[N.B.—This Handbook has been corrected up to April, 1904; any alterations which may be suggested should be forwarded to Chief Inspector, Royal Arsenal, Woolwich.]

ORDNANCE, B.L. 4-INCH, MARKS V AND VI.

(Plates I and II.)

12-7-38. N.O.S.

Material	steel.
Weight, nominal	26 cwt.
Length, total	120 inches.
Preponderance	9 lbs.
Bore	{ calibre	4 inches.
	{ length	108 inches.
	{ capacity, including chamber	1,570 cubic inches.
Chamber	{ diameter	5.3 inches.
	{ length	18.5 inches.
	{ capacity	417 cubic inches.
Rifling	{ system	polygroove (hook section).
	{ twist	increasing from 1 turn in 120 calibres at breech to 1 turn in 30 calibres at 43.77 inches from muzzle; remainder uniform, 1 in 30.
	{ length	88.77 inches.
grooves	{ number	24.
	{ depth	0.04 inch.
	{ width	0.4 inch.
Venting	axial.
Obturation	pad.
Means of rotation	copper driving band.
Angle of deflection for drift	1° 30'
Radius of sights	37 inches.
Firing mechanism	percussion.
Ballistic effects	{ muzzle velocity in f.s.	1,900.
	{ „ energy in ft.	626.
	{ penetration of W.I. at 1,000 yds. in inches	5.4.

A plane for the reception of the clinometer is prepared on the upper side of the guns at the breech.

Guns on travelling carriages have a removable band, furnished with a pivot for attaching the elevating gear, fitted over the jacket at the breech (*see* carriage, page 14). A steel bracket (Plate V) for carrying the telescopic sight is firmly attached to the face of the right trunnion by a dovetail and two fixing screws; a bronze adjusting screw is provided in the upper part of the bracket for altering the position of the telescope when required to correct for difference of level of wheels.

Guns on garrison carriages have an elevating arc attached by two screws.

Mark V Gun.—The gun is made entirely of steel, and consists of the A-tube, jacket with trunnions, 1 B and 2 B hoops, hood and four chase-hoops.

The A-tube ceases at the breech end on a level with the face of the screw, which gears into the jacket, so that the longitudinal strain is borne by the exterior metal.

The jacket is shrunk on to the A-tube at the rear and locked in position by a short turn, which brings a ring of interrupted projections on the inner surface of the jacket, in front of a similar row of projections arranged round the A-tube. The hollow spaces are afterwards completely filled up by wedges driven in with a taper corresponding to the slots in the gun. One wedge would be sufficient to keep up the jacket, but by driving in wedges all round continuity of metal is preserved for transmission of strain in a circumferential direction.

The 1 B, 2 B, 3 B, 4 B, 5 B, and 6 B hoops are shrunk over the A-tube in front of the jacket extending to the muzzle, the 2 B hoop partially overlapping the 3 B hoop.

The hood is attached by screws to the jacket to protect the breech fittings.

Mark VI Gun.—This differs from Mark V as follows:—Chase-hoops are replaced by one tube designated the B-tube, and the 1 and 2 B hoops are made in one, and designated the B hoop.

The following is a description of the mechanisms of the guns:—

Breech Mechanism.

(Plate III.)

The breech is closed by a screw having three portions of the thread removed longitudinally, each one-sixth of the circumference. The interior of the gun at the breech being prepared in a similar manner, admits of the screw, when the raised portions are placed opposite the smooth surfaces in the gun, being pushed home, and locked by the sixth of a turn.

The breech-screw, A, has hinged to it a cam lever, B, by which it is locked and unlocked; the cam portion of this lever (when the breech-screw is locked) falls into a recess in the carrier ring and so prevents any movement of the breech-screw during firing. In depressing the cam lever after the breech-screw is unlocked, the cam acting upon the surface of the carrier ring partially withdraws the breech-screw together with the obturator.

Encircling the rear end of the breech-screw, and hinged to the "hood," is a carrier ring, C, which supports the screw when withdrawn.

On the outer face of the breech-screw is a lug, which, coming in contact with a projection on the carrier ring, forms a stop when the screw is unlocked.

The carrier ring is held to the gun during the withdrawal of the breech-screw by a "clip" pivoted within the left side of the ring, engaging with a recess in the hood.

A stop bolt in the right side of the carrier ring prevents the breech-screw being disengaged from the carrier when withdrawn; at the same time the clip is disengaged from the recess in the hood by means of a spring, which forces its opposite end into a recess in the breech-screw, thus securing the latter in the carrier ring. When in this position the whole can be swung clear of the breech opening, to admit of loading.

In closing the breech, the upper arm of the clip is elevated by coming in contact with an inclined plane in the hood, and the clip being pivoted, is consequently released from the recess in the screw, leaving it free to be pushed home.

Obturation.

(Plate III.)

The system of obturation consists of a circular pad, D, with front and rear protecting discs, E, fitting the mouth of the chamber, being placed between the mushroom head of the axial vent and the breech-screw.

The pad, being slightly elastic, expands radially when compressed by the action of the powder gas, thus sealing the escape.

To prevent play owing to slightly varying dimensions of the pads, and their becoming compressed by firing, one to four (as required), thin adjusting discs of steel are placed between the rear protecting disc and the face of the breech screw. (See also page 7.)

The obturating pads should weigh as follows, and if any are found not to be within these limits, steps should be taken to exchange them for others:—

	Minimum.	Maximum.
Weights ..	0-lb. 15-oz. 8-drs. ..	1-lb. 1-oz. 4-drs.

Firing Mechanism.

(Plates III and IV.)

The percussion firing arrangement is designed to prevent the gun being fired before the screw is in its locked position.

It consists of a steel vent, G, passing through the longitudinal axis of the breech-screw, having secured to its outer end a box, I, in which the percussion lock slides, the latter being pushed into a position over the vent, when the breech is being closed by a bolt gearing with a cam-groove in the carrier ring, and by the action of an inclined spring guide on the carrier. Should there be a projecting tube in the vent, the spring of the guide yields, to prevent the shearing of the tube.

The percussion lock consists of a frame (a) containing a hammer (b), actuated by the mainspring (c). The hammer is retained in its elevated position by a trigger (d). A sliding hammer guard was

formerly fitted to the frame having upon the upper surface two parallel rectangular projections, placed immediately under two similar projections (*g*) on the hammer, but as it was found that these projections were apt to become worn, and thus cause miss-fires, the hammer guard, together with its spring and fixing screw, have been removed. Locks that have been altered in this manner will have a * added to their Mark. The cavity caused by the removal of the hammer guard is left unfilled, but locks of future manufacture will be made without this cavity.

The lock, which acts automatically with the closing of the breech, contains a striker (*h*) for transmitting the blow from the hammer to the tube. A lanyard bolt, having one side bevelled, corresponding with the end of the trigger, is placed in the slide box; when the lanyard bolt is pulled, the trigger is pressed, thereby releasing the hammer. The cam groove in the carrier ring retains the lock in such a position that the striker is not immediately over the tube till the breech-screw is locked. Without opening the breech, the guide bolt (*k*) can be withdrawn from the cam groove, to allow the lock to be drawn back for inserting a tube in the vent, or changing it in case of a miss-fire. Particular attention is called to these instructions, as to the insertion of the tube. The tube is never under any pretext whatever to be inserted *before* the breech is closed. When the breech is open the lock is retained in the grooves of the slide box by a spring stop pin.

A lanyard guide is provided to admit of the gun being fired from the right-hand side. It is of bronze or steel, and is furnished at one end with a sheave for the reception of the lanyard, the other end is pivoted in a steel bracket, which is intended to be tightened round the cam lever of the gun in such a manner as to ensure a straight pull in a line with the axis of the lanyard bolt to the outer edge of the sheave. A set screw is fitted to the bracket in order to retain the guide in the correct position, a hole being drilled in the cam lever for its reception.

For lanyards used. (See page 11.)

Notes on the foregoing Mechanisms.

Vent.—Axial vents, owing to the use of vent sealing tubes, last in good order for a very large number of rounds, and seldom require to be changed, as they need not be condemned till the enlargement becomes considerable, or the scoring appears to be excessive, and likely to hold smoldering pieces of cartridge.

If, at practice, the vent becomes choked with residue from the cartridge, it should be cleared with the "rimer, vent, axial," sufficiently to allow of the insertion of a tube, which, when fired, will remove the rest of the obstruction.

Clip Carrier Ring.—If, when opening the breech, the carrier ring remains fast, owing to the clip not working properly, the latter can be pushed back by inserting a vent bit in the hole provided for this purpose on the side of the breech.

Concentricity of Striker.—When examining the breech fittings, care must be taken to test the concentricity of the striker with the tube in the vent. For this purpose a "gauge, striker, eccentricity" is provided, which is suitable to fit in the tube chamber of the vent; in the head of the gauge is a removable plug, upon which the position of the striker point is indicated when the striker is cocked and released with the gauge in position. If the indent made by the striker point in the gauge is found to be so much eccentric as to be likely to cause miss-fires with either percussion or electric firing, further examination

should be made to ascertain the portion of the mechanism in fault, and steps taken to have it repaired or exchanged.

De Bange Obturator.—Obturation is obtained by means of a mushroom headed axial vent of steel, passing through the centre of the breech screw, with a pad and a pair of metal discs. The inner face of the breech screw is flat, and between it and the head of the vent the pad and discs are arranged. The pad is made of asbestos, worked up with mutton suet to a proper consistency, and enclosed in a strong canvas cover; it is reduced to shape, and pressed in a hydraulic machine. The pad is enclosed between two tin discs, the outer angles of which are protected by steel rings. The gun is slightly coned at the seat of the obturator when pushed home, and the pad is provided with a corresponding taper to ensure a good fit.

The discs are stamped with the words "Front" and "Rear" respectively, and the pads have the words "Front" stencilled on the side which corresponds with the front disc, and "Rear" on that which corresponds with the rear disc, in order that they may be correctly assembled on the vent.

In putting the obturating pad on the vent, first place the front protecting disc with its rounded side fitting the back of the mushroom head, then the pad with that side to the front which is curved to fit the front disc, the stitched side being to the rear, then the rear protecting disc, and in placing this, its flat side and the bronze ring with which it is bushed should be on the opposite side to the pad.

If correctly assembled the whole should fit together compactly.

Should the obturator be found not to fit the cone seating in the gun correctly (and this can be ascertained by covering the seating lightly with grease and seeing that the obturator is covered all over, after the breech has been closed and opened again) adjusting discs should be added one by one until the breech closes a little tightly through the obturator being pressed forward into its seating. To admit of the adjusting disc being placed behind the obturator a clearance of about $\frac{1}{10}$ th of an inch is provided in the breech fittings to allow of the vent being moved forward, but the whole of the clearance would seldom be required.

Owing to the unavoidable slight differences in the dimensions of the seating for the obturator in the guns, it is necessary that the first time any pad is used in any particular gun it should be with a full charge and projectile. Pads issued in guns may be taken as already expanded, so that in such cases the first round need not be with full charge and projectile. Any spare pads should be used with a full charge at the first practice after receipt. (*See also Care and Preservation.*)

The pads are almost indestructible, except, perhaps, from the wear of opening and closing the breech, but, if contracted, they should be soaked in a hot mixture of olive oil and tallow, or if swollen or warped, and difficulty is experienced in getting the fittings into position, they should be warmed through till soft, placed in position, the breech closed, and in each instance the pad compressed while warm until the slide box can be placed in position.

The outer canvas of the obturating pad should be free from rents; small bruises likely to be removed by the pressure of firing are of no importance.

If the pad is not in good order, or there are too many adjusting discs behind the pad, stiffness in working the breech will probably result. The obturating pad should be rubbed occasionally with Russian tallow mixed with oil, or some other suitable lubricant; and the pad with protecting discs should be carefully handled to prevent their being indented or bruised.

The protecting discs should also be carefully examined, and if the tin be fused, or the steel rings eroded, burred, or cracked, they should be replaced by new discs.

The obturating pads and discs should be kept complete on the vent in the gun, or under pressure in the box provided for the purpose, as there is a tendency of the pad to swell in the direction of its axis, which might cause difficulty in adjusting it on the breech screw.

When the obturator is attached to the breech screw, the removal of the latter from the carrier ring should be done by two persons, as care is necessary to keep the "clip, retaining carrier ring" pressed up clear of the breech screw, before drawing the breech screw back to avoid damaging the obturating pad and discs. The obturator should, however, always be detached, when possible, from the breech screw before removing the latter from the carrier ring.

Action.—When the breech screw is pushed into the gun, the obturator enters the chamber with perfect ease; on turning the breech screw, the obturating pad is pressed home into the coned seat in the gun by the travel of the screw. The bore is thus perfectly closed by a species of buffer in contact all round the circumference, while the mushroom head of the vent receives the force of the gas on discharge. On firing the gun the pressure acts on the mushroom head of the vent and compresses the pad against the breech screw, causing it to expand laterally; from symmetry of form and position, this expansion must be radial to the axis and equal in every direction, and is sufficient to prevent the escape of the gas. On the pressure being removed, elasticity comes into play, and the obturator can be withdrawn from the cone by a straight pull, which can be given so soon as the screw is unlocked.

REMOVING AND REPLACING BREECH FITTINGS.

Instructions to be observed in removing and replacing the breech mechanism.

Care must be taken not to indent or damage the components; a hammer should never be used unless with a piece of wood or soft metal to transmit the blow.

The fittings should be examined frequently as to their condition in respect to wear, in order that, if necessary, special examination may be called for.

To Remove the Fittings.

Before removing these fittings, the breech should be opened. By drawing back, by the aid of the extractor tube P, or other suitable tool, the spring stop pin that secures the sliding piece of the percussion lock, the latter can be removed.

The slide box at the outer end of the axial vent is held by two keys secured with keep pins; on taking out the latter, the keys and the slide box in two parts can be withdrawn; the obturator can then be removed.

The obturator should always be removed from the breech-screw before the latter is withdrawn from the carrier ring.

When the breech is open, the breech-screw is held in the carrier by a stop bolt on the right and by the "clip carrier ring" on the left; the stop bolt can be pushed out to the front and withdrawn on lifting up the clip and moving the breech-screw forward.

By pressing the "clip carrier ring" upwards after removing the stop bolt, the breech-screw is released, and can be withdrawn to the rear.

The cam lever is hinged by a bolt with keep pin.

The carrier ring is attached by a hinge bolt, secured by a keep pin; on taking out the latter, and giving a few taps with a piece of wood to the hinge bolt underneath, it can be withdrawn upwards.

The "clip carrier ring" is held in a slot in the carrier by a bolt.

A "latch carrier ring" for retaining the carrier open, was formerly fitted to the carrier ring, but this has now been removed and the cavity filled with a preserving block.

The inclined spring guide for the percussion lock is held by a keep pin.

To Replace the Fittings.

This is the converse of the above.

APPURTENANCES, &c. (*Demandel separately*).

SIGHTS.

The gun is sighted on both sides. The sight sockets on the right side of the gun are fitted with preserving plates and plugs, when telescopic sights are issued with guns on 6-ft parapet carriages.

The foresight is of the usual drop pattern, and consists of a steel pillar, fitted with a steel acorn point, a bronze jacket and socket, the latter is permanently fixed in the gun. The pillar and jacket lock into the socket by a bayonet joint. The sight is stamped with the letter "E" as a means of identification.

The tangent sight is of steel, the bar being square in section. The front face is graduated to 20°, and is made with a rack for gearing with the pinion of the "Clamp, tangent sight, automatic, A." The rear face is furnished with a crown-metal range strip which is graduated to 7,600 yards for a full charge, and the bar is stamped with the muzzle velocity and the kind of charge used, P. or C. The cross-head is furnished with a screw deflection leaf, giving deflection of 2° right and left.

Telescopic Sight.—This sight is carried in a bracket on right trunnion of gun, *see* p. 4; the description and instructions for using it, &c., are published in a separate handbook.

BOX, OBTURATING PADS AND DISCS, B.L. 4-INCH GUN AND 5-INCH HOWITZER.

(*Plate VI.*)

Mark I box differs from Mark II in having iron fittings and screws, instead of metal fittings and brass screws.

Mark II box is of wood, the sides being made of deal, ends and bottom of elm; top, battens, and internal fittings of mahogany, the sides are dovetailed to the ends, and the bottom is secured by brass screws. It holds three pads and three sets of discs.

The box is fitted with a false lid (*a*), a gunmetal bolt passes up through the bottom and both lids; each lid is secured with a fly nut (*bb*), both nuts being on the before-mentioned bolt. The false lid

thus secures the pads and discs in the box by having the fly nut screwed down upon it (*see* also Care and Preservation of Ordnance in "Regulations for Care and Preservation of War Matériel, &c.")

Round the top of the box, under the lid, sheet felt is secured with shellac and tacks, to make a tight joint.

On top of the lid there is a metal plate which has a folding down handle for lifting purposes, secured by screws; there is also a recess to contain a label of instructions.

The interior of the box is coated with paraffin wax, and the exterior is painted.

For dimensions, *see* the Plate.

CLINOMETER, LARGE, MARK I.

The instrument is fitted with a metal drum, which is graduated to 45 degrees. For method of using the clinometer and its care, *see* page 49. When not in use the clinometer is kept in its leather case or wood box; the latter will be obsolete when stock is used up; either is a separate store to the clinometer.

IMPLEMENTS.

The following implements are used with the guns:—

Bit, vent, 23-inch (or 20-inch).

Extractors, tube $\left\{ \begin{array}{l} P. \\ P \text{ special.} \end{array} \right.$

Gauge, striker, eccentricity.

Gauge, striker, protrusion.

Ordnance, B.L.—

Wrench, breech action.

Rimer, vent, axial, short (Mark IV).

The above-mentioned implements will hardly need to be described, except, perhaps, the following:—

Extractors, Tube P (Mark I). P special (Mark I). Plate VII.—Vent-sealing tubes require particular means to withdraw them from the vent. Two instruments are provided, one for ordinary use, and the other for *special* use when the tube is jammed beyond the power of the other.

To use the former the lock is first drawn back, and the jaws of the extractor are inserted under the head of the tube on the side opposite the lock; the handle of the extractor is depressed, thus loosening the tube, which can then be withdrawn from the vent.

The special extractor consists of a sheath, containing a bolt with a screw thread on the inner end, and two small levers hinged to the outer end, which is square in section to prevent turning inside the sheath. A revolving cross-handle actuates the threaded portion of the bolt, moving it in or out, according to the direction in which the handle is turned. A small bar between the levers causes them to diverge on passing out of the sheath; and their outer ends, which are semi-circular in form, are lipped so as to clip the head of the tube.

When using this extractor, it will be found convenient to remove the percussion lock. The cross-handle is then turned till the ends of the levers protrude sufficiently to admit of their being placed over the head of the tube. On turning the cross-handle in the opposite direction, the tube is gripped and forcibly extracted.

Either end of the cross-handle serves as a wrench for the securing nut of the striker in the percussion lock.

SIDE ARMS, &c.

Brush, piasaba, B.L., bore, 4-inch, Mark II. The brush is used for cleaning the bore of the gun, in conjunction with a sponge cloth or piece of canvas tied on the head.

The head is of elm, having piasaba tufts secured into it by pitch or marine glue.

The stave is of ash, and is secured in the head by a copper rivet. It is fitted with a metal socket joint, which consists of a metal plug fixed to the stave end, and a metal cylinder fixed to the brush stave; the plug is inserted in the cylinder, and secured in position by a thumb screw fitted to the cylinder.

Total length, with end stave, 10 feet $6\frac{1}{4}$ inches.

Stave end, B.L., or Q.F.C., 4-inch gun and B.L. 6-inch howitzer.—This is for lengthening the stave of the piasaba brush, as above described; it is of ash, fitted with a metal plug to suit the socket joint.

Length, 4 feet $7\frac{1}{2}$ inches.

Rammer and sponge, B.L. 4-inch.—Mark I. The rammer is of ash, the head and stave being in one piece, the head is protected in front by a brass ring, and the circumference is covered with fleecy hosiery.

Total length of combined rammer and sponge, 4 feet 6 inches.

Lanyard, Cocking.—This lanyard is made of tarred white line, with a spherical wood toggle stamped "C," at one end, and at the other end a hook for hooking to the hammer of the percussion lock of guns mounted on travelling carriages.

Length 15 to 18 feet.

For guns mounted on Vavasseur garrison carriages the length of the cocking lanyard is 18 inches.

Lanyard, Friction tube, Siege, No. 2.—This lanyard is also of white line tarred, with cylindrical wood toggle, hook, loop, and auxiliary lanyard with hook, for guns mounted on travelling carriages.

Length 15 feet.

For guns mounted on Vavasseur garrison carriages the lanyard is 2 feet long.

Cover, breech, B.L. 4-inch gun.

Cover, muzzle, No. 4.

These covers are of water-proofed canvas, and are respectively secured to the breech and muzzle by a leather strap.

CARE AND PRESERVATION OF ORDNANCE AND FITTINGS AND AIMING RIFLES.

See also "Regulations for Care and Preservation of War Matériel, &c."

The breech fittings should be kept clean, oiled or greased, and in good working order; all working surfaces should be well lubricated, the fittings being taken off sometimes for this purpose, especially after firing.

All fittings of the gun should be treated with care; violence and jerks should be avoided, and no unnecessary force should be employed.

The breech fittings should work easily and be free from cracks and burrs; the latter can be removed by filing, but this must be done carefully so as not to permanently damage the fitting. Should a crack be observed in a breech fitting, such fitting should be exchanged.

The threads of the breech screw should be free from burrs. Should the screw not work easily when the obturator has been detached, the defect may often be remedied by careful filing, but no portion of the thread should be cut away to remove a crack.

Causes which lead to stiffness in working the breech :—

1. Pad not in good order.
2. Too many adjusting discs behind the pad.
3. Striker percussion lock too long or worked loose.
4. Guide bolt of percussion lock driven hard against the side of cam groove.

The removable elevating band where in use should be examined to ascertain that it has not shifted from its proper position, thereby causing strain and damage to the elevating gear.

On the line of march, the breech should be kept covered to prevent dust and grit getting about the fittings, and so impede their easy working, a canvas breech cover is supplied for this purpose. There is also an expanding tampeon or canvas cover for closing or covering the muzzle.

RIFLES, AIMING, M.H. CHAMBER, EWART.

(Plate VIII.)

This apparatus is designed for use with either M.-H. ammunition or aiming-tube cartridge, and is for use with the gun in imparting instruction in laying, and consists of the following parts:—

Rifles, aiming, M.-H. chamber, Ewart, 4-inch—

Bands*	Bronze.
Front, B.L. 4-inch	With securing bolt, nut, and washer, hinge-bolt, collar, and keep-pin.
Rear, B.L. 4-inch	With securing bolt, nut, and washer, buffer, and key.
Barrel, rifle	M.-H. rifle barrel, with breech action and metal boss.
Cord, firing, 2 yards.	White line, tarred, with 2 hooks, for guns other than B.L. 6-inch.
Link, trigger	Bronze, with fixing screws.
Tube, 0.23-inch "J"	Morris, with breech-piece, bushes (movable and fixed), set nut, and leather washer; rifles, aiming M.-H. chamber, Elswick and Ewart (identical with tube, aiming, M.-H. rifle).

Appurtenances.

Tube, 0.23-inch—			
Brush, cleaning	36 inches.
Key, M.-H.	
Rod, cleaning	36 inches.

* Brackets, which will be attached to the gun by screws, will in future manufacture be provided instead of bands.

Method of Fitting, Adjusting, and Using the Apparatus.

The aiming rifle is fitted to the left side of the gun in the following manner:—

The two bands are placed over the exterior of the chase of the gun, and secured with bolts, the distance between the inner faces of the bands being 27 inches.

The muzzle of the rifle is passed through the hole in the arm projecting from the front band, and the breech is placed in the socket on the rear band, and fastened with a key. A buffer spring, to lessen the strain on recoil, fits into the socket in rear of the rifle. A hole is made at the rear end of the socket to facilitate the extraction of the buffer spring.

To adjust the rifle on the gun, the latter is laid horizontally; the 0.23-inch tube, "J" is then inserted in the bore of the rifle; sufficient length being allowed to project from the bore to admit of the application of a spirit level to the 0.23-inch tube, by which means the rifle is levelled, so that the axes of rifle and gun are in parallel horizontal planes. The bands are then firmly screwed up, care being taken to see that they do not shift during the operation, in the event of which they must be slackened and readjusted.

Elevation is obtained by means of the gun sights, and any error in line is corrected by use of the deflection scale.

The rifle is fired by means of the firing cord, one end is hooked to the loop of the "Link trigger," and the other end to the service "Lanyard, friction tube, siege, No. 1," and a straight lead from the trigger is obtained by passing the lanyard round the left tangent sight, or the breech of the gun to the firing number.

Care and Preservation.

The actions and parts of the rifle and tube should be kept perfectly clean and oiled, so as to keep them in good working order and prevent rust. No cutting material, such as emery cloth, is to be used for cleaning.

Ammunition.

.45-inch barrel .. Cartridge, S.-A. ball, M.-H. rifle, solid.
.23-inch tube.. .. Cartridge, aiming tube.

(For description, see page 26.)

CARRIAGES AND SLIDES, B.L. 4-INCH.

(Plates IX to XII.)

Description.	Elevation.	Depression.	Height of Axis of Trunnions in firing Position.	Weight.
Carriage, travelling, B.L. 4-inch, 6-feet parapet, Mark I	°	°	ft. in.	cwt.
	25	5	6 6*	Carriages 29
Carriages, garrison, B.L. 4-inch, { Mark I	20	30	..	7
Vasseur { ,, II	20	14	..	8½
				Slides
Slides, L., B.L. 4 inch, Vavas- { Mark I	2 6½†	21½
seur { ,, II	2 6½†	13½

* Above the ground.

† Above the racer.

CARRIAGE, TRAVELLING, B.L. 4-INCH, 6-FEET PARAPET
MARK I.

(Plate IX.)

The carriage is constructed to fire over a 6-foot parapet, with 25° elevation and 5° depression.

It is fitted with a hydraulic buffer in tension, which allows 5 feet recoil, and by which it is attached to a central pivot plate, bolted on a double-decked platform.

The carriage consists of two steel lattice girder brackets, connected by transoms, a solid steel axletree (1st class, B, No. 11) which is formed into a ring in the centre for the hydraulic buffer to pass through, and two 5-foot wheels (1st class, B, No. 7), with steel tires 4 inches wide, and steel naves.

The elevating gear, which is on the right side of the carriage, consists of a worm spindle worked by a hand wheel, transmitting motion through a worm wheel and spindle pinion to an arc pivoted to a removable elevating band which is secured on the gun by two cotters with pins. The worm wheel is fitted with a friction cone to allow a slight slip each time the gun is fired, to reduce the strain on the elevating gear.

The hydraulic buffer consists of a steel cylinder or tube, with a wrought-iron front and rear cap, piston, with piston rod of steel, an inner and outer gland (both of metal), and one L leather. The caps of the cylinder are screwed on and secured by a screw. The front cap is furnished with trunnions for the connecting stays; it is also prepared for the inner gland, which has the outer one screwed into it, the inner face of the inner gland bearing against a packing leather of L section reduces the escape of liquid. A filling hole is provided on top, in front of rear cap, fitted with a plug having a handle to facilitate action and a draw-off valve under the front of the buffer. The piston is provided with four .425 inch holes for passage of liquid; it is screwed on to the rod, and prevented from turning by a check-screw which is inserted in the joint, and in latest manufacture it is coated with plastic metal to prevent seizure during recoil. The piston rod has a steel shackle screwed on to the front for connecting it to the radial arm of the platform. A loose trunnion ring round the cylinder works in metal bearings in the axletree ring, which admits of the buffer being placed either in the firing or travelling position; the opening in the centre transom of the carriage for the buffer to pass through is made to clear the handle of the filling plug when the buffer is being removed. When in action the piston rod is secured to the radial arm of the central pivot plate, and the buffer cylinder is attached to bearings on the axletree by steel connecting stays, one of which is secured to each side of the front cap.

Action.—When the carriage is “run up” before firing, the piston rod is home in the cylinder, and the liquid is in front of the piston. On recoil the cylinder is drawn off the piston and rod, and the liquid is forced behind through the holes in the piston, the resistance of the liquid to the force of recoil brings the gun to rest.

For travelling, the piston rod is disconnected from the radial arm, and the connecting stays from the loops; the buffer is then pushed towards the rear through the trunnion ring, in which it is free to move, and then supported on an angle-iron bar fixed across the trail. The detached ends of the stays are next raised and fastened by pins to metal brackets on the breast of the carriage, and a chain secured to

the breast on one side is passed through the shackle on the piston rod and made fast on the other side.

The carriage is fitted with trunnion bearings and housing brackets for travelling, loops for shifting tackle, loops and hooks for the drag shoe, a hinged wood step on each side for loading purposes, and a wood step on the trail for laying the gun. When travelling, the laying step is carried at the rear of the front transom, and the loading steps are folded up and secured to the sides of the carriage.

It is also fitted to carry the following stores, viz.: 5 handspikes, 1 rammer, 1 pair of pincers, and 1 water-brush, on the "off" side; a pocket for "extractor, tube, P," on the "near" side; 1 McMahon spanner and 1 hammer between the trail; and a shifting roller strapped to the centre transom. For further detail, see page 51.

Length of carriage, with wheels	11 feet 8 inches.
" axletree	6 " 5 "
Track of wheels	5 " 2 "
Working contents of buffer	13 $\frac{1}{4}$ quarts.
Weight	22 cwt.
Wheels (two)	7 "
Tonnage	8.309 tons.

LIMBER* (SIEGE WITH BOX), TRAVELLING, B.L. 5-INCH AND 4-INCH.

(Plate X.)

The limber is that used with all wrought-iron siege carriages, the "axletree, 2nd Class, C, No. 92," with its bed, constituting a box girder.

The wheels are "2nd Class, C, No. 35A or 39, steel nave, 11-inch pipe, 5 feet diameter, 3-inch tire."

The shafts are one pair, "near" and "off," of the ordinary field pattern (except that the "off" shaft is fitted with a loop for attachment of the outrigger stay); and another pair framed, siege pattern, attached to the splinter bar. Outriggers for four-horse draught are also provided.

The limber is arranged to carry one large box, viz.: "Box, limber, travelling, B.L. 5-inch and 4-inch, 6-ft. parapet, Mark I, (wood, store)" which is fitted to contain the loose parts and stores for the gun, a list of which is appended, page 51.

In addition to the stores carried in the limber store box, provision is made to carry a proportion of spare parts in "Box, store, B.L. 5-inch and 4-inch, 6-ft. parapet, Mark I, wood" (one store box to ten guns), which will be carried in one of the wagons in park.

A list of the stores carried in these two boxes is given on the packing diagram, page 51.

					cwts.	qrs.	lbs.
Weight	{	Limber	6	3	22
		Wheels	4	2	4
		Limber box (empty)	1	0	22
		Store box (empty)	1	0	18

* In movable armaments the limber, siege, R.M.L., can be used with carriage, travelling, B.L.

VAVASSEUR CARRIAGES AND SLIDES.

A number of B.L. 4-inch Vavasseur Mountings have been adapted for drill purposes in the land service.

CARRIAGE, GARRISON, B.L. 4-INCH VAVASSEUR (MARK I.) | L. |

ADAPTED FROM NAVAL BROADSIDE, MARK II.

(Plate XI.)

The carriage (*a*) admits of 20 degrees elevation and 30 degrees depression. It is a solid gunmetal casting, consisting of two brackets (*b*) and transom (*c*); in each bracket is formed a cylinder, which is closed in rear by a gunmetal cap and fitted in front with a large and a small gland (outer and inner respectively), and a ring L-section leather, the cylinders are connected by a passage through the transom for the fluid. The piston rods are in tension, by being secured to projections on the front of the slide by means of nuts. The pistons are fitted with collars, the latter are made to revolve by means of projections which slide along spiral grooves inside the buffer cylinders; these collars are arranged to close the openings in the piston gradually as the carriage recoils, the pressure in each buffer being equalised by means of the before-mentioned passage through the transom. The recoil is $10\frac{1}{2}$ inches (metal to metal 12 inches).

Gunmetal cap squares are provided for securing the gun, each slides into position from the outside and is secured by a pin.

Elevating Gear.—This gear consists of a pinion (*d*) gearing with an arc (*e*) which is attached to the gun by two screws; this pinion is on the same shaft as the worm-wheel (*f*) which is driven by a worm sliding on the shaft (*g*), the latter being provided with a hand wheel for actuating the gear. The arc allows of 20 degrees elevation and 30 degrees depression, a yard scale plate is fitted to it and the range is read off by the aid of a pointer.

This gear should be in proper adjustment, otherwise it will either slip by being too loose, or jam if too tight. The pinion and elevating arc should be wedged up, and the adjusting nut of the friction cone tightened up until the power of one man applied at the hand wheel (*g'*) is sufficient to revolve the worm-wheel.

The electrical firing gear is described at page 20.

For *slide*, see page 17.

CARRIAGE, GARRISON, B.L. 4-INCH VAVASSEUR (MARK II.) | L. |

ADAPTED FROM NAVAL C.P., MARK I.

(Plate XII.)

The carriage (*a*) is similar to the Mark I, before described.

It admits of 20 degrees elevation and 14 degrees depression.

The recoil allowed by the hydraulic buffer is $13\frac{1}{2}$ inches (metal to metal $14\frac{1}{2}$ inches).

For electric firing gear, see page 20.

For *slide*, see page 18.

SLIDE, L., B.L. 4-INCH, VAVASSEUR (MARK I). | L. |
ADAPTED FROM NAVAL BROADSIDE, MARK II.

(Plate XI.)

The slide (*h*) consists of two cast-steel sides, having a slope of 15 degrees to admit of running up after recoil; they are connected by bottom plates in front and in rear. The slide is fitted with two front and two rear rollers, traversing gear, front buffer stops (*i*), pivot plate, and a bracket for supporting the electric battery; a pointer to facilitate reading the angle of traverse is attached to the slide by means of a bracket.

Traversing Gear.—This gear consists of a pinion (*j*), shafts and bevel gear. The pinion is in gear with a rack which is laid in the emplacement, motion being transmitted by means of the hand wheel (*k*).

The following special pivot block and pivot plug, racers and traversing arc are used with this mounting; also implements, &c.

BLOCK, PIVOT, No. 32 (MARK I).

PLUG, PIVOT, No. 20 (MARK I).

The pivot block is of steel, 1 foot 10½ inches long, and 4 inches diameter, the lower end is split and diverged so as to hold in the concrete in which the pivot is embedded to the level of the racers.

The pivot plug is of steel, 5¼ inches long, and 1½-inch diameter.

RACK, TRAVERSING, SLIDE, B.L. 4-INCH, MARK I, VAVASSEUR
(MARK I).

This rack is of steel, made in three segments, which are bolted together; it is laid in concrete at a radius of 44 inches.

RACER, SLIDE, B.L. 4-INCH, MARK I, VAVASSEUR { FRONT (MARK I).
REAR (MARK I).

These racers are of steel, 1-inch thick and with flat soles; they are each made in two segments, which are connected by means of a 1-inch steel plate and rivets. The racers are secured to lewis nuts by screws, the lewis nuts being set in the concrete.

Radius { front racer 33.57 inches.
rear racer 66.0 inches.

ARC, TRAVERSING, No. 28 (MARK I).

This traversing arc is of gunmetal, in two sections, each one being made in segment lengths, the outer section having the degree figures engraved in it and the inner the divisions, each division being subdivided into four. The sections are secured to lewis nuts by means of screws, the nuts being set in concrete. The angle of traverse is read off by means of a pointer on the slide.

Radius of arc, 6 feet.

SPECIAL IMPLEMENTS.

Spanners, Hydraulic Buffer.—These are of steel. No. 7 is for plugs filling and emptying. No. 9 is for large gland and cap.

Spanner.—No. 201, this is of steel, for cone and pinion nuts elevating gear.

(5506)

B

SLIDE L., B.L. 4-INCH, VAVASSEUR (MARK II). | L |.

ADAPTED FROM NAVAL C.P., MARK I.

(Plate XII.)

The slide (*b*) is of cast steel, and mainly consists of two sides, which are connected by two transoms and bolt, mounted on a pivot plate. The upper part of the sides are similar to the Mark I slide. It is fitted with one front and two rear rollers, and is held to the pivot plate by clip plates, two in front and two in rear, which engage under the outside rim of the pivot plate.

Traversing Gear.—This consists of a worm and shaft (*c*), the worm engaging with a worm wheel or ring fixed on the pivot plate (which see), a first motion pinion, second and third motion spur wheels on spindles, motion being transmitted to them by the handwheel (*d*) on the first motion spindle.

Pivot Plate.—This is of steel and is firmly secured to the emplacement by screws and Lewis nuts, the latter being set in concrete; the upper circumference of the pivot plate forms the roller path, and a projection in the centre forms the pivot upon which a cavity in the slide fits; round this projection is secured the traversing worm wheel.

SPECIAL IMPLEMENTS, &c.

Loop, lifting worm.

Spanners, hydraulic buffer } these are the same as for Mark I
Spanners } carriages and slides.

CARE AND PRESERVATION OF CARRIAGES AND SLIDES.

See also "*Regulations for Care and Preservation of War Matériel, &c.*"

For Carriage, Travelling, B.L. 4-inch, 6 feet Parapet, and Limber.

The footboard joints should be cleaned and oiled.

The box on limber should be removed occasionally and examined underneath. Care must be taken to prevent the lodgment of water on any part.

When carriages are parked, or placed in a shed with the shafts exposed, the latter should be raised on the props to keep the points dry.

Defects or damage must be made good without delay; if the paint becomes rubbed off at any part of limber it should be patched over as soon as possible.

Particular attention must be paid to the elevating gear to preserve it in good order, and the friction cone should be occasionally removed and slightly oiled to prevent the formation of rust, which would cause it to get set fast in the worm wheel and so prevent it acting. Care must be taken in replacing the cone to see that it is properly adjusted to give the necessary slip for preventing injury to the gear.

If it is required to remove the hydraulic buffer from the carriage, the small keys at the rear of the axletree ring must be extracted, and the buffer can then be slid through the ring.

Hydraulic Buffer.—When the packing in the gland of the hydraulic buffer becomes worn, its pressure on the piston rod is lessened, hence leakage, and the metal gland must be screwed up; if this does not stop the leakage, the gland must be repacked.

The principal parts of the hydraulic buffer are as follows:—

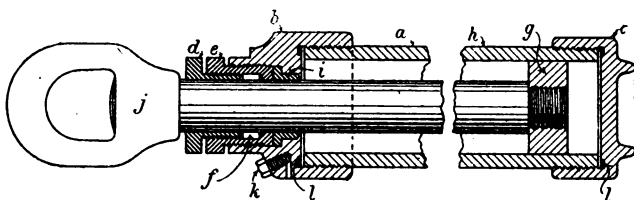

- a. Cylinder or tube, steel.
- b. Cap, front, steel.
- c. " rear, "
- d. Gland, inner, metal.
- e. " outer, "
- f. Packing, round white cotton rope 2-inch, length of 24 inches.
- g. Piston with rod, steel.
- h. Plug, filling hole, steel.
- i. Ring, packing leather, L section.
- j. Shackle, steel.
- k. Valve, draw off.
- l. Washers, cylinder or tube.

To Replace Packing of Hydraulic Buffer.—Remove the shackle from the piston-rod, and unscrew the inner gland; then with the tang of a file extract the defective packing. Next unscrew the outer gland, and by drawing out the piston-rod the L leather ring will come out also, clean out the glands and slightly coat them and the piston-rod with mineral jelly. Place the new L leather on the rod, taking care not to damage its thin edge, and screw it home with the outer gland. Insert the new cotton rope packing in the stuffing box of the outer gland, using a piece of wood, or former, and tighten up the packing with the inner gland. The cotton rope rings must be about a quarter of an inch less in length than the circumference of the piston-rod, and have the ends bound with cotton yarn. When required for use they must be well greased with tallow, and placed in the stuffing box, so that the ends when brought together do not coincide, but arranged so as to break joint with one another, so that there will be no direct passage for the liquid past them; in screwing home the gland care must be taken not to over-tighten it, for excess of friction may be thrown upon the rod, which would interfere with its proper action.

To fill the Buffer.—Push the piston-rod well home in the cylinder, take out the screw plug from the filling hole, and by means of the gallon measure fill the cylinder; then draw off one quart.

Contents of the buffer $13\frac{1}{4}$ quarts of mineral oil.

Oil is withdrawn from the front screw valve, air being let into the cylinder at the same time by the removal of the screw plug.

Before action see that the cylinder contains the requisite quantity of oil; that there is no leakage in the glands; that the buffer is properly attached to the carriage; and that the piston-rod is securely shackled to the radial arm of the pivot.

For Carriages, Garrison, B.L. 4-inch Vavasseur, Marks I and II.

To Replace Packing of Hydraulic Buffer.—Remove the nuts from the front of the piston-rods, run back and secure the carriage, so as to get at the glands, which with the packings can be seen to as before mentioned for the 6-feet parapet carriage, as they are similarly arranged in the cylinder formed in the carriage sides. In this case "packing, hydraulic, $\frac{1}{4}$ -inch square" is used, a length of 72 inches being allowed which will be cut into lengths forming rings, each about equalling the circumference of the piston-rod; the cuts will be made diagonally, so as to overlap when the piece is formed into a ring; well tallow each ring, press them successively into the stuffing box with a piece of wood, or former, taking care that the joinings are well separated so as to break joint as already stated.

Contents of the buffers 14 pints of mineral oil.

ELECTRIC FIRING.

GUNS ON VAVASSEUR GARRISON CARRIAGES AND SLIDES.

Emplacement Firing.—This gear generally consists of a wooden battery box, two Le Clanché cells, two cables, and a McEvoy firing key.

The two "cells, electric, Le Clanché A (Mark III)" are fitted in and connected up in the wooden box; they are issued with the sal ammoniac in them and sealed; all that is required to make them ready for use is to fill them three parts full with water, and to see that this is added from time to time to make up for evaporation (*see* Care and Preservation, page 21).

Two lengths of "cable, electric, unarmoured, D 13" (single core braided), one cable is about 9 feet long (over all) with a McEvoy firing key (*x* Plates XI and XII) fitted to it at a convenient point to admit of the gun layer firing, the other cable (for return current) is also of the same length. The cables have fitted to them, at one end a brass point connection to fit in the sockets of the electric vent-sealing tube wires, and at the other ends a metal socket and washer connection for binding on to the terminals of the battery box.

These terminal metal sockets are made locally when required; they are made in the form of a washer with a socket at one end for the reception of the lead, the core of which is passed through the small hole *a*, *see* sketch, and soldered.

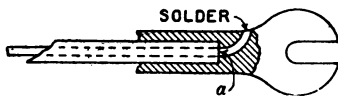

To facilitate the attachment of the cables to the battery box a celluloid "segment" is attached near each terminal, and a celluloid "sleeve" near the end of each cable, the sleeves on any one cable, and segment being in one distinguishing colour.

Position-finding Firing.—The leads from the P.-F. firing circuit terminate at the P.-F. safety firing plug box or dial box recess in the emplacement. From thence to the firing tube suitable lengths of

cable are provided (locally). After firing, the cables should be put well clear, so as to prevent their being cut by the slide when traversing.

Full particulars as to position-finding arrangements will be found in a separate handbook.

CARE AND PRESERVATION.

See also "Regulations for Care and Preservation of War Matériel, &c."

Battery.

The two Le Clanché cells are issued with the sal ammoniac in them; all that is required to make them ready for use is to fill the cell three parts full of water, and to see that this is added to from time to time to make up for evaporation.

When the battery fails to fire a tube, fresh saturated solution of sal ammoniac should be added, the old solution being thrown away.

The solution is easily made up, by putting crushed sal ammoniac into boiling water, until the sal ammoniac will no longer dissolve, and a saturated solution is formed which should be allowed to become quite cold, and then poured carefully into the cell and some dry crystals added, to make up for loss by evaporation; in about 12 hours the cell should be ready for work. If the cells still fail to fire the tube they should be exchanged and inspected.

The cells are insulated by being painted or paraffined. Either process protects them from accumulations of films of damp, dust, or dirt, or depositions of salt out of the liquid, due to what is termed "creeping." The cells should be made secure in the box.

To prevent "creeping," all cells should be kept dry and clean, and for this reason they should be enclosed in painted or varnished boxes.

The connections of the battery must be kept bright.

Wires.

Electric wires or light cables should be perfectly free from kinks and insulated to prevent as much as possible waste of current.

They are issued sheathed in insulating material, but joints should be covered or insulated with the materials as allowed by Equipment Regulations.

In making joints the ends should be prepared by being thoroughly cleaned by scraping or with emery cloth or sand paper.

PLATFORM, SIEGE, DOUBLE-DECKED, C. PIVOT, MARK I.

(Plate XIII.)

The platform consists of two layers of 3-inch fir planks, those of the bottom layer parallel to the line of fire, those of the upper layer at right angles to it. Under the bottom layer are placed four transverse planks similar to those in the top layer, one at the front and one at the rear of the platform, the other two dividing the distance between them, one being 4 feet 6 inches from the front, and the other 5 feet 3 inches from the rear transverse plank; distances measured in the clear.

The planks of the upper layer are connected at each end to those below by 5-inch coach screws.

Both layers of planks are connected to the four transverse planks by 8-inch coach screws.

The platform consists of the following parts:—

	No.
Bottom layer planks, 18 feet × 9 inches × 3 inches ..	16
Top layer planks 12 „ × 9 „ × 3 „ ..	24
Transverse planks 12 „ × 9 „ × 3 „ ..	4
Screws, coach, square-head { $\frac{5}{8}$ „ × 5 „ ..	40
{ $\frac{3}{8}$ „ × 8 „ ..	62

The siege carriage, fitted with hydraulic buffer, whether mounted in permanent works or in hastily-constructed positions, will be attached to a pivot plate with radial arm, fixed to the double-decked platform; wheel plates and trail plank are used. These are described hereafter, Plate XIII shows the pivot arrangement attached to the platform, &c.

PLATE, PIVOT, DOUBLE-DECKED PLATFORM.

(Plate XIII.)

The pivot plate (*a*) is a circular steel casting, with a hole bored in the centre, to suit either the pivot plug or the boss of the radial arm (*b*). It is secured in position on the double-decked platform by 12 bolts which pass through the planks, and a circular steel holding-down plate on the underside of the platform. Mark II is of lighter construction than Mark I.

Dimensions, &c.

Weight (with plugs and bolts Mark I) ..	11 cwt. 1 qr. 10 lbs.
Tonnage	0·3475 ton.
Dimensions (over all)	4 feet 1 inch × 10 feet.

ARM, RADIAL, PIVOT, DOUBLE-DECKED PLATFORM.

(Plate XIII.)

The radial arm (*b*) is a steel casting with a clip formed at the front end to grip the projecting rim of the pivot plate, and so prevent the arm lifting when firing. It is secured to the pivot plate by one clamping and two jamming screws; the clamping screw can be readily removed to admit of the arm being placed in different positions to suit any angle of traverse. The piston rod of the buffer is attached to the radial arm by the pin (*c*). Mark II is of lighter construction than Mark I.

Dimensions, &c.

Weight (Mark I)	2 cwt. 0 qr. 12 lbs.
Tonnage	0·989 ton.
Dimensions (over all) 3 feet $4\frac{3}{4}$ inches × 1 foot $7\frac{3}{4}$ inches × $8\frac{1}{2}$ inches.	

PLATE, WHEEL, PLATFORM, SIEGE.

The wheel plates are of steel. One is placed under each wheel of the carriage to protect the upper layer of the platform.

Dimensions, &c.

Weight..	1 cwt. 2 qrs. 10 lbs.	
Tonnage	0.0094 ton.	
Dimensions	6 feet 0 inch	×	1 foot 6 inches	×	$\frac{1}{2}$ inch.

PLANK, TRAIL, SIEGE (Mark II).

The trail plank is of oak, 12 inches × 3 inches × 6 feet, shod on both sides for the whole of its length with channel steel, and fitted with four rope handles. It is to be placed under the trail of the carriage to preserve the ground platform from injury. It should be placed under the centre of trail, the end projecting about 6 inches in front of trail. The plank should be in the line of recoil.

IMPLEMENTS.

Spanner, No. 156, Mark I—This is a socket spanner for coach screws of the Mark I platform only.

 PLATFORM, SIEGE, DOUBLE-DECKED, MARK II.
(Plate XIV.)

This platform is similar to the Mark I, before described, but it is only 12 feet long and is more easily laid. It consists of two layers of 3-inch deal planks, the bottom layer being parallel to the line of fire, the upper layer at right angles to it. Under the bottom layer are placed three traverse planks (or transoms (*a*)) similar to those in the top layer, as shown in the Plate. Under the front is bolted an oak baulk (*b*), 9 inches square, to receive the eyebolts of the holdfast formerly used. The two layers of planks are secured to the transoms by 8-inch bolts, and to the front baulk by 14-inch bolts. A riband of deal, 6 inches by 3 inches, is placed on top of the outer edges of the planks on each side of the platform, and bolted through to the transoms by three 12-inch bolts, and to the front baulk by an 18-inch bolt.

A thin washer plate for each bolt is placed under the pivot plate on top of the upper planks, and on top of the transoms under the bottom planks, which, by means of split keys passing through the bolts, prevent the bolts slipping down while the nuts are being screwed up.

A steel binding plate, 4 inches by $\frac{3}{8}$ -inch is attached to each outer side of the platform by 13 $\frac{1}{2}$ -inch coach screws, 3 inches long.

The 1-inch square headed bolts securing the planks are now provided with special nuts, so that one spanner (No. 185) will suit the nuts of the 1-inch and $1\frac{1}{4}$ -inch bolts of the platform and pivot plate respectively. The recesses in the platform for the special nuts should be enlarged if necessary.

for the service cartridge. A handle of tarred rope is attached to the cartridge by passing the ends of rope through the holes from the top to the holes in the side of cartridge and knotting each end of rope.

The 3-lb. 1-oz. cartridge is also made of a block of wood, having a circular hole bored from the top down the centre to a little below the middle of the cartridge, into which is inserted lead, to bring the cartridge up to weight of the service cartridge, the remaining portion of the hole is closed with a wood stick, glued to the wood block. The cartridge is covered with raw hide, the dimensions correspond to those of the service cartridge.

PACKING.

The service cartridges are issued packed in metal-lined cases. A whole metal-lined case will hold 9 12-lb. S.P., or 35 3-lb. 1-oz. cordite cartridges, or 29 4-lb. blank.

SECURING M.-L. POWDER CASES, STACKING, &c.

See "*Regulations for Care and Preservation of War Matériel and Magazines.*"

Cartridges for Aiming Rifle and Aiming Tube.

CARTRIDGE, S.-A., BALL, M.-H. RIFLE, SOLID.

Mark I cartridge is obsolete.

Mark II cartridge. The case is made of solid drawn brass with a cap chamber formed in the base; the case has a paper lining up to the shoulder.

The cap is of brass, and contains 0.3 grains of cap composition pressed and varnished, and there are two fire holes in the rim round the anvil.

The charge is 85 grains R.F.G.² powder. Above the powder is placed a glazed board disc, then a wad of beeswax, which is cupped out to the front to insure its expansion in cold weather, and then two more glazed board discs.

The bullet is of 12 parts lead and 1 part tin, and weighs 480 grains; it has one cannellure.

Cartridges of this description are packed heads and tails in bundles of ten; a bundle weighs 1 lb. $4\frac{3}{8}$ oz.

A S.-A. A. box will contain 580 rounds and will weigh, when filled, about 85 lbs. 9 oz.

CARTRIDGE, AIMING TUBE.

Mark I case is of solid drawn brass with a cap chamber and anvil in the base; two fire holes in the anvil allow the flash to pass from the cap to the charge, which is $3\frac{1}{4}$ grains "Curtis and Harvey's Diamond No. 2" powder; over it are wads and a bullet of pure lead.

Mark II differs in the arrangement of the wads.

Packed 100 in a cardboard box and issued, usually, 10,000 in a tin-lined box.

PROJECTILES.

(Plates XVII to XX.)

Description.	Mark.	Diameter.		Length.	Bursting charge.		Weight filled and fuze in the case of shells.
		Body.	Band or studs.		Nature.	Weight.	
Shell, B.L., Q.F., or Q.F.C. 4-inch—		inches.	inches.	inches.		lb. oz.	
Common { iron ..	III, VIII	3·96	4·11	11·37	P. & F.G.	1 12	} 25
{ forged		"	"	12·70	"	2 12	
{ steel		V, VI	"	"	13·20	"	
Shrapnel (F.S.)..	V, VI	"	"	10·3	F.G.	0 1½	} 25
	VII, VIII	3·97	4·105	10·64	"	0 3	
Shot, B.L. 4-inch—							
Case.. ..	I	3·95	4·1	9·45	} 25
Paper, empty ..	I	3·75	4·11	16·25	

The bursting charges given in the above table are P. and F.G. powder for common shell, in the proportion of 2 lb. P. to 5 oz. F.G. powder, and R.F.G.², R.F.G., F.G., or pistol powder for shrapnel shell.

SHELL, B.L., Q.F. OR Q.F.C. { IRON, MARKS III AND VIII | C |
COMMON, 4-INCH { FORGED STEEL, MARKS IV TO VI | C |

(Plates XVII and XVIII.)

Marks I and II were of cast iron and differed principally from other Marks in their driving bands, Mark I being provided with an Elswick ring and Mark II with a narrow Vavasseur driving band.

Mark III is of iron, cast to finished dimensions, without bands, and unturned. The head is struck with a radius of 2 diameters, the point being truncated, bored out, and fitted with a gunmetal bush, tapped to G.S. fuze-hole gauge, and countersunk 0·2-inch to receive the naval wad. Rotation is imparted to the shell by a copper driving band, which is pressed into a groove near the base. The interior of the shell is lacquered, and the bursting charge is contained in a dowel bag, to avoid premature explosion through friction when the powder sets back on the shock of discharge (*see also page 29*).

Mark VIII differs from Mark III cast-iron shell in having the groove for driving band undercut; the front slope of the driving band is now serrated so as to grip in the gun when loading.

Mark IV differs from the above in being of forged steel. It is rather longer and has the head struck with a radius of $2\frac{1}{2}$ diameters. On account of the greater strength of the steel, the walls of the shell are much thinner than those of Mark III and allow a larger bursting charge to be used (*see Table*).

Mark V is also of forged steel, but longer and with thinner walls, thus allowing of a still larger bursting charge. The gunmetal bush is also longer, to allow of the use of a G.S. wad below the small percussion fuze.

Mark VI only differs from Mark V in having the driving band half an inch farther forward.

SHELL, B.L., Q.F. OR Q.F.C., SHRAPNEL, 4-INCH, MARKS V TO VIII
| C | F.S.

(Plates XIX and XX.)

Marks older than V are obsolete, but any still in charge will be used up for practice.

Mark V shell is 2.57 calibres long, the head is truncated and struck with a radius of 2 diameters, the bursting charge is in the head. The shell is rotated by means of a copper band, as in the case of the common shell, the band having cannelures.

The head and body (except the base) are made in one piece, of forged steel. The base is attached to the body by six twisting pins and two keys, the latter fitting into slots cut in the body and base.

The body is filled with mixed metal balls (230 at 22½ to the lb.) and resin up to the commencement of the head, where an iron disc and felt washer are placed over them; above the washer is a cylindrical tin cup to contain the bursting charge. The upper end of this tin cup fits round the bottom of the gunmetal G.S. fuze-hole socket, which is screwed into the nose of the shell; the remaining space over the cup and round the socket is filled by a wood block.

Mark VI shell differs from Mark V in having the groove for driving band undercut; the front slope of the driving band is now serrated, so as to grip in the gun when loading.

Mark VII shell is made of forged steel, 2.63 calibres long. An undercut groove near the base contains a plain copper driving band, i.e., the band is without cannelures, but the front slope is serrated. A tin cup, to contain the bursting charge, is fitted in the base, over which is a steel disc, which is screw-threaded to receive a metal central tube; this tube is screw-threaded at the top to receive the primer for carrying the flash from the fuze on to the charge, the tube and metal socket for fuze being connected by tin soldered to each.

The shell, which is lined with brown paper, is filled with about 169 bullets (22½ per lb.) and resin, on top of which is a felt wad.

The head is of steel and struck with a radius of 2 diameters; in the head is soldered a metal socket which is taped to G.S. fuze-hole gauge, the space between the socket and steel head being filled up by a wood block. The head is attached to the walls of the shell by screws and twisting pins, and rounded off with solder.

Mark VIII differs from VII shell in the groove for driving band, which has "waved" ribs with three chisel cuts made across them; with this form of attachment the band is less liable to turn or strip off.

SHOT, B.L., CASE, 4-INCH | L | .

(Plate XVII.)

Mark I shot has a body made of XX single tin in three pieces soldered together; the bottom is soldered to the sides of the body, which are turned over it; a copper cup is riveted to the bottom, and a disc of sheet iron laid loose inside; six studs of lead and antimony

are cast on the bottom end of the shot above the copper cup to grip the slope in front of chamber of gun. The interior is lined with three wrought-iron segments 0.22 inch thick, and is filled with 245 mixed metal balls ($16\frac{1}{2}$ per lb.) = 15 lbs. 5 ozs., the interstices being filled in with clay and sand. The top is of iron, fitted with a wrought-iron handle, and fixed by turning the top of the body, which is notched to a depth of 0.35 inch, over with solder.

Drill and Practice Projectiles.

SHELL, B.L., DRILL, 4-INCH | L | .

This is of cast-iron, fitted with two copper bands of 3.96 inches diameter to prevent injury to the rifling in loading and unloading. The nose is bushed with gunmetal, and the base is fitted with a large hollowed and flanged nut of gunmetal; a groove is formed between it and the metal of the shell to take a rope grummet, which prevents the shell being rammed too far home. It is weighed up with sand to an average weight of 25 lbs.

SHOT, PAPER, EMPTY, B.L. 4-INCH | L | (WITH BUNG).

Paper shot is made of wood pulp, and consists of a cylinder which is plugged at each end, the plugs being secured to the body with oak pins; the top plug has a filling hole which is stopped with a cork bung. The shot is painted with Japan black lacquer; it is issued empty, and when required is made up to weight by a mixture of No. 5 small shot and sawdust; it is stencilled "not to be fired with cordite."

As the projectile breaks up on firing, the small shot travel but a short distance (about 200 yards), while the effect, for purposes of testing recoil, &c., is practically the same as that obtained with the service projectiles. It will therefore be issued for use in time of peace, where the use of the service projectiles would be dangerous or inconvenient.

There will, no doubt, be emplacements from which, owing to the close vicinity of houses, it may be undesirable to use the shot in the normal line of fire. In these cases it will be often found possible, owing to the very short range of the paper shot, to find sufficient space to the right or left of the regular range to carry out such test practice as may be required.

BAGS, BURSTER, B.L., COMMON, 4-INCH $\left\{ \begin{array}{l} \text{IRON} \\ \text{FORGED STEEL} \end{array} \right| \begin{array}{l} \text{C} \\ \text{C} \end{array} \left. \vphantom{\left\{ \right.} \right| :$

These are for holding the bursting charges of common shells, to prevent premature explosion through friction when the powder sets back on the shock of discharge. The bags are made of dowls with shoulder and neck of shalloon, and choked with twine, the shape corresponding with the interior walls of the respective shells.

STRIPS, AUGMENTING, B.L. 4-INCH.

Augmenting strips are intended to be used with B.L. projectiles, in cases where the rifling of the gun has, owing to firing, become so worn that the gun ceases to properly rotate its projectiles. They are, however, not to be used with projectiles having the gas check driving

band, and the use of the strips is restricted to projectiles having the broad Vavasseur driving band. The strips consist of copper, of even section throughout, straight, and grooved on one side; their length varying with the calibre of the gun with which they are to be used, this calibre being stamped on them.

Method of Insertion.

The top cannellure in the driving band is to be undercut all round on both sides by means of a special chisel supplied for the purpose, but the projectiles now have the cannellures of their driving bands undercut during manufacture, and stamped U, and no preparation for the insertion of the strips will be necessary. The augmenting strip is then inserted in the cannellure, grooved side of strip inwards, and lightly hammered until the two tongues of metal, formed by the groove on the inner side of the strip, are dovetailed into the undercuts in the cannellure.

If the gun is very much worn, and one strip is found insufficient to impart the proper rotation, a second may be inserted in the lower cannellure in addition.

The number of rounds which may be fired from the 4-inch B.L. gun before augmenting strips must be used is (probably) 739.

As regards wear of bore, blank charges may be reckoned to have a quarter the effect of full charge with projectile.

EXTRACTOR, DRILL SHELL, NO. 1 (MARK I) | L | .

This is of steel, with wood stave. The steel portion is formed to hook the base plug of drill shell and a socket in which the stave is secured by two wrought-iron rivets. A spiral groove is cut on the out outer end of the stave to prevent the hands slipping.

Total length, 5 feet.

PREPARATIONS OF PROJECTILES, FIXING FUZES, &c.

See "*Regulations for Magazines, &c.*"

FUZES.

Plates XXI to XXIII.

Percussion, Small, No. 8.

Time and percussion { Short, No. 55.
No. 56.

Drill, T and P, No. 56, Mark I.

FUZE, PERCUSSION, SMALL, NO. 8.

(*Plate XXI.*)

Mark IV fuze consists of the following parts:—

Body, detonator pellet, with two retaining bolts, spiral spring, safety-pin, closing pellet, needle plug with steel needle, and magazine.

The body is of gunmetal, screwed on the outside to the G.S. gauge. It is bored out from the top to receive the detonator pellet, and is closed by means of the needle plug. Two holes, closed on the

outside by brass discs, are bored in the body to receive the retaining bolts of the pellet. Two fire-holes are bored in the bottom to communicate the flash from the pellet to the magazine, which consists of a pierced pellet of pressed powder, secured in the lower end of the fuze by a brass disc spun in.

A detonator, covered by a brass washer, 0.03 inch thick, and having a tinfoil disc, subsequent to 27th June, 1894, under it to prevent the detonating composition working through the fire-holes, is secured in a recess in the top of the gun-metal pellet, and two fire-holes filled with F.G. powder, lead from it to the bottom, where they are closed with paper discs. The top of the pellet is reduced to fit inside a spiral spring, which prevents the pellet rebounding or working forward during flight.

The two retaining bolts, with brass spiral springs, pass transversely through the pellet (as shown in the drawing), the springs keeping them locked in the holes in the body until spun out by the rotation of the shell. A screw in the body projects into a groove down the side of the pellet, and prevents it from turning.

The needle plug has a steel needle fixed in the centre, and screws into the top of the body. A hole through the side of the fuze into the needle plug contains a brass pellet, with spiral spring behind it, for closing the safety pin-hole.

The safety-pin, of twisted copper wire, passes through the needle plug, down the body, behind the head of one of the retaining bolts, and is bent over at the top into a groove in the needle plug.

Mark III differed from the above in having the detonator pellet held in position by a small screw plug, and in having no protecting washer over the detonator. In Mark II the spiral spring in front of the detonator pellet was found stronger, and was replaced by the same spring as in Mark III, the fuze being then Mark II*, which was identical with Mark III. Marks II* and III will be exchanged for Mark III* or IV.

Mark III fuzes are converted to practically the same as Mark IV, and are then Mark III*.

The safety pin-hole and closing plug for the same, and all openings made in the body, are now finally painted with Pettman cement.

Action of the Fuze.—The safety-pin being withdrawn at the moment of loading, the hole is closed by the closing pellet. On discharge the centrifugal motion of the shell causes the retaining bolts to fly outwards, leaving the detonator pellet free to move forward. On impact, the pellet compresses the spring in front of it, and moves forward on to the needle, which ignites the detonator, and so fires the fuze.

Weight of fuze, $6\frac{1}{4}$ ozs.

FUZE, TIME AND PERCUSSION, SHORT, No. 55, MARK III.

(Plate XXII).

The fuze is made of gun-metal turned and screwed to suit G.S. fuze-hole. The dome is pressed or drawn to shape and unturned; the interior is bored out at the lower end, and fitted with a needle, detonator pellet, volute spring, retaining bolt, safety pellet, and brass ball, and the bottom closed with a gun-metal screw-plug and shalloon discs. The fuze is fitted with a composition ring made of gun-metal, barrel-shaped outside to facilitate setting, and containing a hammer

and needle, suspended by a copper shearing wire over a detonator covered by a brass disc; a dome is fitted over the composition ring, and secured by a cap screwed on the stem of the body of the fuze, a washer between the cap and dome has a feather which fits in a recess in the stem, so that when the cap is screwed up the dome is not turned with it. The ring is graduated outside from 0 to 18, each division being subdivided into four; an arrow-head between 0 and 18 shows the position of safety. The body has an arrow-head on it for use in setting the fuze. The fuze has two safety-pins—one through the safety pellet of the percussion arrangements, and one under the hammer of the time arrangement, each having a loop of tarred whipcord attached, that for the time-pin being now scarlet.

To fix the fuze, insert the point on the hemispherical arm of the "Key, fuze, universal" in the small hole in the circumference of the body of the fuze, and screw the latter tightly into the fuze-hole.

The fuze should be set after it is fixed in the shell.

Loosen the hexagonal cap on the top of the time fuze by means of the slot in one of the arms of the key, which will fit over it, and then turn the dome and collar of the fuze together until the required graduation on the collar coincides with the arrow-head on the body, and tighten the cap. This should be done *before the removal of the upper safety pin*. The nut should be screwed down as tightly as possible. With guns on travelling carriages when the fuze is set at the gun, the socket on the trail is used instead of the fuze-key.

If required to act as a time and percussion fuze, withdraw both safety pins before inserting the shell; if the percussion arrangement is not required to act, the lower safety pin should be left in; if the fuze is required to act on *percussion only*, the upper safety pin should *not* be removed, and the arrow-heads should be set to coincide.

Action.—The fuze is screwed into the nose of the shell, and the safety pins withdrawn at the moment of loading. On shock of discharge, if the time safety pin has been withdrawn, the wire through the lighting needle is sheared, and the needle fires the detonator which ignites the composition in the ring, which burns (according to graduation) until it reaches the mealed-powder pellet, which it ignites, firing the magazine. The flash then passing through the holes in the needle screw disc, and percussion pellet, fires the fuze.

If the percussion safety pin has been withdrawn, the wire through the safety pellet is sheared, causing the safety pellet to fall into the pocket, thus releasing the ball; the centrifugal motion then causes the locking bolt to fly out, releasing the detonator pellet, which, being free to move forward (on impact) by compressing the volute spring, strikes the point of the needle, thus igniting the detonating composition and firing the fuze.

Mark II differs in being without the washer between the cap and dome, in having the composition ring flat outside, and in having no spring above the detonator of the percussion arrangement. When fitted with a brass spiral spring in front of the detonator pellet, and with hardened needles similar to Mark III, the designation is Mark II*.

Mark I is obsolete for land service.

Time of burning at rest is about 13 seconds when set at 18 or full length.

Weight of fuze, 13 ozs.

When the stock is used up No. 56, Mark IV, will be used.

FUZE, TIME AND PERCUSSION, No. 56, MARK IV.

(Plate XXIII.)

This fuze will always be used with the Marks VII and VIII shrapnel shells.

The fuze consists of the following parts made of gunmetal, except where otherwise stated, viz.:—Body, detonator plug with detonator, percussion pellet, brass spiral spring, base plug, brass safety pellet, brass ball, composition ring, cap, brass washer, dome, two safety pins, and two leather washers.

The *body* is screwed at the lower end to G.S. fuze-hole gauge, and bored from the bottom to receive a percussion pellet and base plug. Two holes are bored beyond the recess for percussion pellet, one for the detonator plug, and the other for the safety pellet. An arrowhead is engraved on the body (a black triangular setting mark has been substituted for the arrow, commencing with the 449th thousand).

The *detonator plug* is screwed on the outside and fitted with a detonator, covered with a brass disc. The hole bored for the detonator plug is continued above it to form a small magazine filled with F.G. powder. In the top of the body is bored a recess to contain a perforated pellet of pressed pistol powder, which communicates with the magazine by a hole, bored at right angles to the axis of the fuze. The stem on the body is screwed on top to take the cap, two grooves being cut in the top end of stem to receive the feathers on the brass washer. A groove is cut in the top face of body, close to the stem and half way round it, and a gas-escape hole bored obliquely through the body into the groove. A small tablet of fine white paper is secured with shellac to the body of the fuze over the perforated powder pellet, and over it, two washers of fine white paper and calf skin are secured with shellac, a hole being cut through the washers and tablet immediately over the powder pellet.

The *percussion pellet* has a slot in the side for the safety pellet and ball to fall into when set in action. A hole is made transversely through the pellet and fitted with a brass retaining bolt, held in position by a brass spiral spring. The pellet contains a powder charge of F.G. powder. A small set screw, in the wall of the body, fits into a slot in the percussion pellet to prevent it from turning in flight. A spiral spring, of brass wire, is placed between the percussion pellet and detonator plug.

The *base plug* contains a perforated pellet of pressed powder, covered with shalloon, and secured by a brass washer spun over on top.

The *safety pellet* has a slot cut in the side to clear the brass ball and is suspended in the body by a thin copper wire passing through it. A hole is also bored in the upper part of the pellet and body of fuze for the safety pin to pass through.

The *composition ring* has a chamber on one side, and three projections on the inside to keep it concentric with the stem of the body. The chamber has a hammer with a steel needle suspended in it by a copper wire over a patch of detonating composition. A safety pin also passes through the hammer and chamber. The ring has a groove on the underside filled with composition, and connected with the chamber by a lighting hole. The outside of the ring is graduated from 0 to 18, each division being subdivided into halves and quarters,

(5506)

c

with a broad arrow at the point, where the groove is interrupted by a bridge soldered in.

The *dome* is made of sheet brass.

The *washer* is made of sheet brass, with two feathers which fit into featherways cut in the top of the stem. When screwing up the cap the washers remain stationary, thus preventing the dome from turning and altering the setting of the fuze.

The *cap* is made of gunmetal, hexagonal in form, and screws on the stem of the body.

The fuze is stamped T on the composition ring close to the time safety pin, which is now fitted with a scarlet cord loop, and P on the body close to the percussion pin.

The fuze should be set *before* the safety pins are withdrawn.

To set the time arrangement, the cap is loosened with the "key, fuze, universal," and the ring moved round until the graduation ordered is exactly in line with the arrow, or triangular mark, on the body; the fuze is then clamped by screwing down the cap as tightly as possible, care being taken that the ring and dome have even bearings.

If the fuze is required to act as a percussion fuze only, the P pin should be withdrawn and the T pin left in position; otherwise, both pins should be withdrawn, but this should not be done till the moment of loading.

Action.—On discharge, if the time safety pin has been withdrawn, the hammer sets back, shearing the suspending wire, and igniting the detonator and the time ring, which burns until it comes over the pellet, and so flashes down through the radial magazine, detonator pellet, and base plug, and into the shell.

If the percussion pin has been withdrawn, the safety pellet sets back, shearing the suspending wire, and the brass ball falls down into the space over the safety pellet. The centrifugal bolt, owing to the rotation of the shell is withdrawn, the percussion pellet is free to move forward on impact and ignite the detonator, which flashes through the percussion pellet and base plug into the shell.

Weight, 13 oz.

FUZE, DRILL, TIME AND PERCUSSION, No. 56, MARK I.

In present manufacture, all drill fuzes are, to facilitate identification, stamped "Drill," and bronzed all over, with the exception of the time rings (and a patch showing the index), of drill, time, and percussion fuzes, which are left bright.

This fuze is of the service pattern, but it is issued empty, and is provided with special safety pins which can be withdrawn and replaced as required.

TUBES.

(Plates XXIV to XXVII.)

Tubes, vent-sealing	{	Electric, P., Marks III to VII.
		Percussion, Marks II to VII.
		Electric, P., drill,* Mark III.
		Percussion, drill, Mark I.

The percussion lock arrangement necessitates a special tube for firing the charge, and this tube performs a double duty in sealing the

* When electric drill tubes at present in use are worn out, service tubes will be used.

vent when fired so as to prevent the escape of gas. The tubes, both for service and drill, are made of two patterns, for firing by hand or by electricity.

TUBE, VENT-SEALING, ELECTRIC, P.

(Plate XXIV.)

A full description of the latest pattern of this tube is given below, the other Marks differ in some manufacturing details only.

Marks I to IV are to be used up for drill purposes.

Mark I was similar to Mark II, but the wires were not tinned over, and the bridge was attached to the poles with ordinary solder.

Mark II was of solid drawn brass, in construction similar to Mark III, but the wires were only 18 inches long.

Mark III: the cylindrical portion of the body was entirely filled with powder, the end being closed by a cork and paper disc, and the wires 1 inch shorter than in Mark IV.

Mark IV: the wires were laid in two slots in the head, and passed through by separate holes, then through an asbestos plug and small air space, and soldered to two brass poles embedded in a conical ebonite plug, and the bottom end is closed with a sulphur pellet in which is embedded a brass ball. *It must not be used unless the range is clear.* See also Notes, p. 37.

Mark V is similar in construction to Mark VI, but it has the brass ball, as in Mark IV, and the same precautions are necessary.

Mark VI is identical in construction to Mark VII, but the wires are led through a groove across the head instead of the V-shaped groove, and it is without the extra 5 inches of oiled silk wrapping on the wires.

Mark VII is made of brass bored out to receive the arrangement for firing by electricity. The interior of the body near the head is conical. A hole is drilled in the head, through which pass two tinned copper wires twisted together, and insulated by varnished silk; on the interior the wires are parted, and led through a V-shaped groove across the head, they are then twisted together again, and wrapped with oiled silk for a length of 5 inches, and terminate in spirals 22 inches from the tube; the spirals are covered with sarcenet. In the interior near the head are two cones, the larger one fitting into the recess in the body, the small one fitting into a conical recess in the large cone; they are insulated from each other and from the body by ebonite. The front end of one of the wires is attached to the rear end of the large cone, and the end of the other wire passes through the large cone, insulated from it, and is attached to the rear end of the small cone. A copper pole is fastened to the front end of each of the cones, the cones being connected by a platinum silver wire bridge embedded in priming composition. The remainder of the tube is filled with pistol powder (in present manufacture pellet powder is used), the end is closed with a varnished cork, and shellaced paper disc, and in latest manufacture a paper disc is placed over the cork plug to prevent it sticking to the cork bottom of the tube box.

Action.—The wires from the battery are connected to the wires of the tube, and on a current of electricity being passed through them, the bridge becomes incandescent, and fires the tube. The cones are jammed into each other and the coned part of the body, and prevent any escape of gas through the head.

Packed five in a tin box.

(5506)

c 2

TUBE, VENT-SEALING, PERCUSSION.†

(Plates XXV and XXVI.)

Mark II tube differs from Mark IV in not having the diagonal fire holes in the anvil.

Mark III is the same as Mark IV, except that the bottom of the tube is closed with a paper disc and perforated brass ball, embedded in sulphur, and secured with shellac. *It must not be used unless the range is clear.* See also Notes, p. 37.

Mark IV.—This consists of a body, anvil, striker, brass washer, percussion cap, copper washer, two paper discs, and a cork plug. The body is made of brass, solid drawn; a hole is drilled through the head to receive the striker, which is secured in position by being riveted into the countersunk washer, as shown in the Plate. The upper part of the chamber is screwed and fitted with an anvil, on which is placed the percussion cap, the upper surface of which is in contact with the striker; a small central and two diagonal fire-holes are drilled through the anvil. The remainder of the space in the tube is filled with loose pistol powder, and the bottom is closed with a paper disc, and cork plug coated with varnish.

Action.—This is the same as Mark VI tube, excepting that the striker of the tube, together with the percussion cap, is driven on to the anvil, thus firing the tube.

Mark V tube differs from Mark VI in the form of the striker, which is without the cup-shaped gas check, and the detonator, which is held in position by a brass screwed collar. The tube is filled with R.L.G.² powder, the interstices being filled up with R.F.G.² powder, but in latest manufacture a special fine grain powder (those filled on or before December 14, 1899, were filled with pistol powder); it is closed with a paper disc, and cork plug coated with varnish. This Mark will be used up for drill and instructional purposes only.

Mark VI tube consists of a body, striker, detonator, detonator holder, two washers, shearing wires, two paper discs, and cork plug.

The body is of solid drawn brass, the head is bored centrally for the striker, detonator, and fire channel. The striker is of brass, with a needle point, and a plain flange at its base, under which is fitted a copper cup-shaped gas check; and it is held in position by a copper shearing wire passed through the tube, and a brass washer in the recessed head of the tube. The detonator is fitted into the holder, and the latter is screwed into the body of the tube. Under the detonator holder is a copper washer, and a disc of fine white paper. The lower part of the tube is filled with R.F.G.² powder siftings, or else a special fine grain powder (present manufacture). The tube is closed with a paper disc and cork plug, which is coated with varnish.

Action.—On firing the gun, the point of the striker of the percussion lock drives the striker of the tube on to the detonator, thus firing the tube, the flash passing on to the charge.

Mark VII generally differs from Mark VI in having the anvil cast solid with the body, a copper percussion cap, and a manganese bronze striker, with blunt point.

The head of the tube is bored out to receive the cap, and a screw plug with the striker. There is a recess round the anvil for the

† Percussion V.S. tubes of present manufacture are blacked, and have four notches cut in the rim of the head to distinguish them from wireless electric tubes by sight or touch. Previous issues of V.S. percussion tubes will be similarly dealt with on passing through the Q.F. for any conversion. This will not necessitate any change of numeral.

reception of the cap, and three fire holes give passage to the flash. The cap is secured in position over the anvil by the screw plug, which is made in two parts, and contains the striker, the latter being kept clear of the cap by the usual copper shearing wire.

The action is similar to that mentioned for Mark IV.

Packed 10 in a tin box.

TUBE, VENT-SEALING, ELECTRIC P, DRILL*.

(Plate XXVII.)

The body of this tube is made of gunmetal in three parts, screwed together and milled outside as shown in the Plate. There are two escape holes through the head, and two holes lined with ebonite cylinders, through which the wire terminals pass and project into the interior to form the poles. The slot in the side of the head is covered by a small brass plate let in; this affords the wires more protection from friction against the percussion lock. The wires are whipped together near the head with black thread, and terminate in spirals 22 inches distant from the tubes. The ends of the wires which project into the interior are connected by a platinum silver bridge soldered to them.

The tube is issued empty. When required for use it will be charged with a small quantity of priming composition, the escape holes being lightly stopped with luting on the outside.

TUBE, VENT-SEALING, PERCUSSION, DRILL.

(Plate XXVII.)

The tube is made of gunmetal, the interior being bored out and the head fitted to receive the coned india-rubber plug, as shown in the Plate. The lower part is closed by a gunmetal plug.

TUBE EXTRACTORS.

(See p. 10, and Plate VII.)

Notes.

In the event of a tube failing to ignite a charge, care should be taken in extracting the fired tube not to stand directly in rear of the gun, as the gas generated will cause the tube to fly out with some violence when eased by the extractor.

The vent sometimes becomes choked with residue from the cartridge. It should be cleared with a "rimer, vent, axial," sufficiently to allow of the insertion of a tube, which, when fired, will remove the rest of the obstruction.

Care must be taken to see that the range is clear when using vent-sealing tubes with ball (Marks IV and V electric, and Mark III percussion), for clearing the vent or any other purpose than regular practice (in which case the range would of course be clear before firing), as the brass ball is projected with considerable velocity by the powder in the tube.

A tube is not to be inserted in the vent till the breech is properly closed.

* See footnote, p. 34.

RANGE TABLE FOR 4-INCH B.L. GUNS, MARKS II, III, IV, V, AND VI.

To supersede Range Table dated 9.8.82.

Based on Practice of 17.5.83, 7.3.84, 21, and 23.4.84.

40185
8672
...
8610

Minutes 4064-5923.

Charge, 12 lb. S.P., or 3 lb. 1 oz. cordite,
size 5.
Projectile, 25 lb.
Muzzle velocity, 1900 f.s.*

Mounting, Vavasseur, or 6-foot parapet
travelling carriage.
Jump, 6 minutes.

Range.	Elevation.	Slope of descent.	Remaining velocity.		5 minutes' elevation increases or decreases the range by	5 minutes will alter point of impact vertically or laterally at each range.	50 per cent. of rounds should fall within			Time of flight.	Fuze scale.	
			l in.	f.s.			Length.	Breadth.	Height.		Short time and percussion fuze. Mark II.	Middle sensitive time fuze.
yds.	° /				yds.	yds.	yds.	yds.	secs.	ins.		
100			687	1853	99.0	0.14	24.0	0.04	0.04	0.15	0.5	0.4
200	0 3		344	1806	95.8	0.29	23.9	0.07	0.08	0.31	0.9	1.1
300	0 8		229	1760	92.7	0.43	23.7	0.11	0.12	0.47	1.3	1.8
400	0 13		164	1715	89.8	0.58	23.6	0.15	0.17	0.64	1.6	2.5
500	0 18		127	1671	86.9	0.72	23.5	0.19	0.21	0.82	2.0	3.2
600	0 23	101	1628	1628	84.0	0.87	23.3	0.23	0.26	1.00	2.4	3.9
700	0 29	84	1585	1585	81.1	1.01	23.1	0.27	0.30	1.19	2.8	4.6
800	0 35	70	1543	1543	78.2	1.16	22.9	0.31	0.35	1.39	3.2	5.3
900	0 42	59	1502	1502	75.5	1.31	22.8	0.35	0.39	1.59	3.6	6.0
1000	0 49	51	1462	1462	72.9	1.45	22.7	0.39	0.44	1.80	4.1	6.7
1100	0 55	44	1423	1423	70.4	1.60	22.6	0.43	0.49	2.01	4.5	7.4
1200	1 3	39	1385	1385	67.9	1.74	21.8	0.47	0.55	2.23	5.0	8.1
1300	1 11	34	1348	1348	65.5	1.89	21.6	0.52	0.62	2.46	5.5	8.8
1400	1 19	31	1313	1313	63.2	2.03	21.4	0.56	0.69	2.69	6.0	9.5
1500	1 27	28	1280	1280	61.0	2.18	21.1	0.60	0.76	2.93	6.5	10.2
1600	1 35	25	1248	1248	58.9	2.32	20.9	0.65	0.83	3.18	7.1	10.9
1700	1 44	23	1280	1280	57.0	2.47	20.7	0.69	0.91	3.44	7.6	11.6
1800	1 53	21	1190	1190	55.2	2.61	20.5	0.73	0.99	3.69	8.2	12.4
1900	2 2	19	1163	1163	53.5	2.76	20.3	0.78	1.07	3.95	8.7	13.1
2000	2 11	18	1138	1138	51.8	2.91	20.0	0.82	1.16	4.21	9.3	13.9
2100	2 21	16	1113	1113	50.2	3.05	20.0	0.87	1.25	4.48	9.9	14.6
2200	2 32	15	1091	1091	48.7	3.20	20.0	0.91	1.35	4.76	10.5	15.4
2300	2 43	14	1070	1070	47.3	3.34	20.0	0.96	1.46	5.05	11.1	16.1
2400	2 54	13	1051	1051	46.0	3.49	20.3	1.00	1.57	5.34	11.7	16.9
2500	3 5	12	1033	1033	44.8	3.63	20.3	1.05	1.68	5.64	12.3	17.7
2600	3 16	12	1016	1016	43.7	3.78	20.4	1.10	1.79	5.94	12.9	18.4
2700	3 28	11	1001	1001	42.7	3.92	20.5	1.15	1.91	6.25	13.5	19.2
2800	3 40	10	987	987	41.8	4.07	20.7	1.20	2.04	6.56	14.1	20.0
2900	3 52	10	973	973	40.9	4.21	20.9	1.25	2.17	6.88	14.7	20.8
3000	4 4	9	960	960	40.0	4.36	21.3	1.31	2.30	7.20	15.3	21.6
3100	4 16	9	947	947	39.2	4.51	22.0	1.36	2.48	7.52	15.9	22.4
3200	4 29	8	935	935	38.4	4.65	22.7	1.42	2.68	7.83	16.5	23.2
3300	4 42	8	924	924	37.6	4.80	23.5	1.47	2.92	8.14	17.1	24.0
3400	4 55	7	912	912	36.9	4.94	24.3	1.53	3.20	8.46	17.7	24.8
3500	5 9	7	900	900	36.1	5.09	25.2	1.58	3.53	8.78	—	25.6
3600	5 23	7	889	889	35.4	5.23	26.1	1.64	3.87	9.11	—	26.5
3700	5 37	6	878	878	34.7	5.38	27.0	1.70	4.21	9.44	—	27.3
3800	5 51	6	868	868	34.0	5.52	28.0	1.77	4.54	9.78	—	28.1
3900	6 6	6	856	856	33.3	5.67	29.0	1.83	4.89	10.13	—	28.9
4000	6 21	6	848	848	32.7	5.81	30.0	1.90	5.24	10.49	—	29.8
4100	6 86	5	838	838	32.0	5.96	31.0	1.98	5.70	11.86	—	—
4200	6 52	5	829	829	31.4	6.10	32.0	2.07	6.20	11.23	—	—
4300	7 8	5	820	820	30.8	6.24	33.0	2.16	6.72	11.60	—	—
4400	7 24	5	810	810	30.1	6.38	34.0	2.25	7.36	11.98	—	—
4500	7 41	4	801	801	29.5	6.53	35.0	2.35	7.88	12.36	—	—

Muzzle velocity with 12 lb. P. has been found to vary from 1980 to 1850 f.s. according to the brand of powder, but with P. powder selected for B.L. guns the muzzle velocity should not vary more than 20 f.s. from 1900 f.s. An increase of 100 f.s. in velocity increases the range at ordinary ranges about 7 per cent.

Range.	Elevation.	Slope of descent.	Remaining velocity.	5 minutes' elevation increases or decreases the range by	5 minutes will alter point of impact vertically or laterally at each range.	50 per cent. of rounds should fall within			Time of flight.	Fuze scale.	
						Length.	Breadth.	Height.		Short time and percussion fuze, Mark II.	Middle sensitive time fuze.
yds.	° /	1 in.	f.s.	yds.	yds.	yds.	yds.	yd.	secs.		
4600	7 58	4	792	28.9	6.68	36.0	2.47	8.43	12.74		
4700	8 16	4	783	28.2	6.82	37.0	2.59	9.00	13.13		
4800	8 34	4	775	27.6	6.97	38.0	2.72	9.64	13.52		
4900	8 53	4	766	27.0	7.11	39.0	2.86	10.31	13.91		
5000	9 12	4	758	26.4	7.26	40.0	3.0	11.0	14.3		
5100	9 31	3	750	25.8	7.41	—	—	—	14.7		
5200	9 51	3	742	25.3	7.55	—	—	—	15.1		
5300	10 11	3	734	24.8	7.70	—	—	—	15.5		
5400	10 31	3	726	24.4	7.84	—	—	—	15.9		
5500	10 51	3	718	24.0	7.99	—	—	—	16.3		
5600	11 12	3	710	23.5	8.13	—	—	—	16.9		
5700	11 33	3	703	23.1	8.28	—	—	—	17.1		
5800	11 54	3	695	22.6	8.42	—	—	—	17.6		
5900	12 15	3	688	22.2	8.57	—	—	—	18.0		
6000	12 36	3	680	21.8	8.71	—	—	—	18.4		
6100	12 57	3	673	21.4	8.86	—	—	—	18.9		
6200	13 19	2	665	21.0	9.01	—	—	—	19.3		
6300	13 42	2	658	20.6	9.15	—	—	—	19.8		
6400	14 5	2	650	20.2	9.30	—	—	—	20.3		
6500	14 28	2	643	19.9	9.44	—	—	—	20.8		
6600	14 52	2	636	19.5	9.59	—	—	—	21.3		
6700	15 16	2	629	19.1	9.73	—	—	—	21.8		
6800	15 41	2	621	18.8	9.88	—	—	—	22.4		
6900	16 6	2	614	18.4	10.02	—	—	—	22.9		
7000	16 32	2	607	18.0	10.17	—	—	—	23.5		
7100	16 59	2	600	17.7	10.31	—	—	—	24.0		
7200	17 27	2	594	17.3	10.46	—	—	—	24.6		
7300	17 55	2	587	16.9	10.60	—	—	—	25.1		
7400	18 23	2	581	16.6	10.75	—	—	—	25.6		
7500	18 52	2	574	16.2	10.89	—	—	—	26.2		
7600	19 22	2	568	15.9	11.04	—	—	—			
7700	19 52	2	562	15.6	11.18	—	—	—			

FUZE SCALE.

Minute 37015 I.—July 20th, 1894.

Gun—4-inch B.L.

Projectile—Shrapnel Shell.

Fuze—Time and Percussion, No. 56, Mark IV (B.L. design, No. 7844A).

Charge—12 lb. S.P.

Range.	Fuze set.	Range.	Fuze set.
100	$\frac{1}{4}$	2,200	$8\frac{1}{4}$
200	$\frac{1}{2}$	2,300	$8\frac{1}{2}$
300	$\frac{3}{4}$	2,400	$9\frac{1}{4}$
400	$1\frac{1}{4}$	2,500	$9\frac{1}{2}$
500	$1\frac{1}{2}$	2,600	$10\frac{1}{4}$
600	$1\frac{3}{4}$	2,700	$10\frac{1}{2}$
700	$2\frac{1}{4}$	2,800	11
800	$2\frac{1}{2}$	2,900	$11\frac{1}{2}$
900	$2\frac{3}{4}$	3,000	12
1,000	$3\frac{1}{4}$	3,100	$12\frac{1}{2}$
1,100	$3\frac{1}{2}$	3,200	13
1,200	4	3,300	$13\frac{1}{2}$
1,300	$4\frac{1}{4}$	3,400	14
1,400	$4\frac{1}{2}$	3,500	$14\frac{1}{2}$
1,500	5	3,600	15
1,600	$5\frac{1}{2}$	3,700	$15\frac{1}{2}$
1,700	6	3,800	$16\frac{1}{4}$
1,800	$6\frac{1}{2}$	3,900	$16\frac{1}{2}$
1,900	$6\frac{3}{4}$	4,000	$17\frac{1}{4}$
2,000	$7\frac{1}{4}$	4,100	18
2,100	$7\frac{1}{2}$		

DRILL FOR 4-INCH B.L. GUN, MARKS V AND VI ON 6-FOOT PARAPET CARRIAGE..

The detachment consists of ten numbers, who fall in two deep, one pace between ranks, No. 1 on the left of the front rank.

TO TELL OFF.

Section Commander.

“... Section, Tell Off.”

At the order from the Section Commander, No. 1 numbers 1, the right hand man of the rear rank 2, his front rank man 3, and so on.

DETACHMENT REAR.

Formed as above, one yard in rear of the muzzle, 1 covering the near wheel.

TO MOVE THE GUN WITH DRAG ROPES.

Section Commander.

“... Section, with drag ropes, Prepare to Advance.”

At the order from the Section Commander, 8 and 9 hand the drag ropes to 2 and 3, who hook them to the drag washers on their own sides. All available numbers man them, the even numbers on the near side, and the odd numbers on the off side; the two highest numbers in the shafts.

PREPARE FOR ACTION.

Section Commander.

“... Section, Prepare for Action.”

TO SHIFT FROM TRAVELLING TO FIRING TRUNNION HOLES.

This must be done while the gun is limbered up as follows:—

Section Commander.	No. 1.
“Shift from travelling to firing trunnion holes.”	“Prepare to shift the gun.”
	“Heave.”
	“Cast off tackles.”

Stores required.—The stores required, in addition to those on the gun, are as follows, viz. :—

Drag ropes, heavy	3
Luff tackles, complete.. .. .	3
Selvagees	2

“Prepare to shift the gun.”—2, 3, 4 and 5 cast loose side arms, handspikes, and fittings. 2 and 3 take off capsquares. 4 and 5 scotch the wheels with handspikes—4 in front, 5 in rear.

No. 1 places selvagee on breech. 4 and 5 hook the double blocks to it, 6 and 7 the single blocks to the loops on the brackets of the carriage. They take in the slack and stand ready for heaving. 9 hooks the double block of a check tackle to a selvagee passed round handle of breech block. 8 fixes the single by a selvagee to trail plate eye. They take in the slack, take a turn with running end round the splinter bar of limber, and pass the fall to the front.

2 and 3 place a handspike in the bore and attach a drag rope to it.

"Ease off and heave."—2 and 3 steady the muzzle, 8 and 9 ease off, remainder haul on the tackles.

"Cast off tackles."—The tackles are cast off by the same numbers that hooked them. 2 and 3 replace capsquares. 4 and 5 connect up the elevating gear.

No. 1.

"Prepare for Action."

1 will see that the gun and mounting are fit and ready in all respects for action. He superintends the other numbers, and provides himself with the clinometer and tube pocket with tubes.

4 depresses the gun sufficiently to allow 2 to open the breech, and straps on the pocket containing the rimer and tube extractor.

3 removes the breech and muzzle covers, and places them in the limber box.

2 opens the breech, and examines the breech screw and threads of the breech, and lubricates them if necessary.

1 sees that the bore is clear; the breech is then closed by 2, and the gun elevated to the travelling position by 4.

7 issues tubes to 1.

9 and 10 see that the ammunition is ready for issue.

TO OPEN THE BREECH.

3 raises the lever to its full extent with his right hand, then with both hands gives it a sharp pull towards him, till hard against the stop, and folds the lever down; 2 then takes hold of the handle of the breech screw with both hands, withdraws the breech screw, and swings it sharply round on its carrier ring.

TO CLOSE THE BREECH.

2 swings the breech screw round, 3 raises the cam lever with his right hand, and 2 pushes home the brush screw with both hands on the handle right hand over left and holds it there until 3 locks it by forcing the lever from him as far as it will go; 3 then folds down the lever.

(2 must be careful to keep his hands clear of the stop on the carrier ring as the breech screw is turned round.)

ACTION.

Section Commander.	No. 1.
". . . . Section, Action Rear" (action Right or Left).	"No. . . . Prepare to Unlimber." "Lift." "Limber, Drive On." "Lower." "No. . . . Action."

At the order from No. 1, "*Prepare to Unlimber*," 2, 3, 4, 5, 6, and 7 stand in to the trail, 2 and 3 nearest the breech. At drill, 8, 9, and 10 go to the shafts. 7 unkeys. 1 gives the order, "*Lift*."* "*Limber, Drive On*." "*Lower*." The limber moves clear as detailed in Heavy Artillery Training. At drill, 6 and 7 push in rear of the limber after the trail has been lowered. (For action right or left, the trail is swung or hauled round a quarter circle.) 1 then gives "*Action*." 1, 2, 3, 4, and 5 remove their handspikes and lay them down point to the front and bevel up, as follows:—

1, in rear of the trail, clear of the recoil. 2 and 3 on their own sides, outside the wheels. 4 and 5 on their own sides, inside those of 2 and 3, and about two feet to the rear.

4 removes the rammer and breech brush, and lays them down on the right of the gun.

1 removes the lanyards from the tube pocket, coils them up, and passes the bights under the tube pocket strap.

2 and 3 open the breech.

4 brings the gun to a convenient position for loading.

5 takes the telescopic sight out of its case.

7 supplies himself with the fuze key.

8 and 10 prepare to issue ammunition.

When recoil scotches and planks are used, 7, 8, 9, and 10 bring them up, and assist 2, 3, 4, and 5 in placing them in position.

POSITIONS IN ACTION.

1.—One yard in rear of the trail, facing the front.

2 and 3.—Close to and in line with the breech, facing inwards.

4.—In line with the trail eye, outside the right wheel.

5.—In a convenient position for the sight he is using.

6 and 8.—With the ammunition (cartridges).

7, 9 and 10.—With the ammunition (shells).

TO FORM DETACHMENT REAR IN ACTION.

Section Commander.

No. 1.

".... *Section, Detachment Rear.*"

"*No.... Double, March.*"

On the order from the Section Commander, 1 places himself three yards in rear of, and covering, the left gun wheel, and gives the order, "*Double, March.*" The numbers double to their places, on the right of 1, each halting as he reaches his place.

TO TAKE POST FROM DETACHMENT REAR IN ACTION.

Section Commander.

No. 1.

".... *Section, Take Post.*"

"*No. . . Double, March.*"

At the order from 1 all the numbers double to their places.

* The trail must not be lifted too high or it will fly up and escape from control

TO LOAD.

Section Commander.	No. 1.
“... Section, ... Shell, Load.”	“No.... Shell, Load.”

7, having fixed and set the fuze, brings up the shell, point to the left; if time fuzes are being used, he shows the fuze to **1**. After **3** has uncapped or removed the safety pins, he places the shell in the bore, and prepares another shell.

9 works alternately with **7**.

4 hands the rammer to **2**, who, with **3**, rams home, and **4** replaces the rammer.

6 brings up a cartridge and hands it to **3**, who places it in the chamber.

2 and **3** close the breech.

1 inserts a tube, and hooks the lanyards.

5, having set his sight places it in the bracket and proceeds to lay.

TO LAY AND FIRE.

2 and **3** pick up their handspikes, and watch for the signals of **5**. **2** and **3** must always endeavour to get the gun into the line of fire without waiting for the signals—directed by **1**.

4 elevates.

The telescopic sight will be removed when laying is completed.

When using quadrant elevation, **5** lays for line, with the sight set at the approximate range. **1** gives the elevation with the clinometer and removes it when the laying is completed.

2 and **3** lay down their handspikes as soon as the gun is laid for line.

Section Commander.	No. 1.
“Fire No.... Gun.”	“No.... Ready.” “.... Fire.”

At the caution, all the numbers stand clear, and **4** picks up the two lanyards; he cocks the lock and drops the cocking lanyard. When **1** sees that all are clear, he orders “*Fire*,” and the gun is fired by **4**. **1** unhooks the lanyards. **2** and **3** open the breech. **4** extracts the old tube, and rimes out.

MISSFIRES.

On a missfire occurring, **4** will at once recock, by means of the lanyard, and fire again.*

If the tube again misses fire, after a pause of one minute (with cordite three minutes). **1** will unhook the firing lanyard, raise the lock, and the tube will be extracted by **4**.

TO RUN UP.

When necessary to move the gun, **1** will apply his handspike under the trail eye; **2** and **3** in rear of the wheels, **4** and **5** over the spokes and under the breast of the carriage, facing the rear.

* If missfires occur, the cocking lanyard should be removed before firing.

CEASE LOADING.

(See Heavy Artillery Training.)

TO CEASE FIRING.

Section Commander.

No. 1.

"... Section, Cease Firing."

"No.... Cease Firing."

The handspikes are replaced, and all the stores drawn at "*Prepare for Action*" are returned.

NOTE.—If the cessation of fire is temporary and the stores are not to be replaced, the order "*Stand Fast*" will be given.

(See also Heavy Artillery Training.)

TO LIMBER UP.

This is the reverse of unlimbering.

TO SHIFT FROM FIRING TO TRAVELLING TRUNNION HOLES.

Section Commander.

No. 1.

"Shift from firing to travelling
trunnion holes."

"Prepare to shift the gun."

"Lift and heave."

"Halt." "Lower."

"Bear down."

"Ease off and heave."

"*Prepare to Shift the Gun.*"—**2, 3, 4** and **5** cast loose sidearms, handspikes, fittings, &c. **2** and **3** remove capsquares, place a handspike in the bore, fix a drag-rope to it, and bear down. **4** and **5** then disconnect elevating gear and run it down. **1** places the shifting roller in position and gives "come up." **4** and **5** scotch the wheels with handspikes, **4** in front, **5** in rear. **1** places selvagee on breech. **4** and **5** hook the double blocks of two luff tackles to it. **6** and **7** the single blocks to the loops on the brackets of the carriage, they take in the slack and stand ready for easing off. **9** hooks the double block of a luff tackle to a selvagee round handle of breech block. **8** fixes the single block by a selvagee to trail-plate eye, they take in the slack and pass the fall to the front. **2, 3, 4** and **5** then stand ready to lift on the handspike in the bore.

"*Lift and heave,*" "*Halt,*" "*Lower.*"—The gun is lifted and heaved to the rear till the trunnions rest on the brackets of the carriage just in rear of the trunnion holes.

"*Bear down.*"—**1** removes the shifting roller **2, 3, 4** and **5** then take post on the easing off tackles.

"*Ease off and heave.*"—Till the trunnions are lowered into the travelling trunnion holes.

DRILL FOR 4-INCH B.L. GUN ON VAVASSEUR C.P.
MOUNTINGS.

The Gun Detachment consists of a Gun Captain, a Gun Layer, and six other gun numbers. It falls in and is told off in the usual manner.

For the duties of Gun Captain and Gun Layer see Garrison Artillery Training.

AMMUNITION SUPPLY.

Cartridges are supplied by **6** from recesses or depôts close to the emplacement.

Projectiles are supplied by **5** or **7** from recesses in or near the emplacement or from depôts which should be arranged under cover of the parapet.

These recesses and depôts will be filled up from the cartridge and shell stores before action commences, and kept replenished as necessary during action, by ammunition numbers

TO PREPARE FOR ACTION.

Gun Group Commander.

Gun Captain.

"A Group, Prepare for Action."

"A1, Prepare for Action."

At th's order stores are brought up as follows:—

Gun Captain.—A piece of chalk.

Gun Layer.—Sights, pointer for traversing arc, percussion lock with spare strikers,* firing battery† and key McEvoy,† two lanyards and screw driver.

2. Tubes, tube box, pocket gun layers, rimer, tube extractor, McMahon spanner, wrench breech action,* oil can,* Russian tallow and waste. For drill, a drill tube.

3. Elevating wheel, if not already on.

4. Combined rammer and sponge, bucket filled with water and sponge cloth.

5. Assists the Gun Layer.

6. Keys of cartridge and shell recesses, two cartridge cases, and for drill, drill cartridges.

7. Brush, key fuze universal, key plug G.S. and grease box. For drill, a drill shell, drill fuze, and shell extractor.

The following group stores will be brought up, and such others as are considered necessary locally:—

Hammers, claw	1 per group.
Whistles	1 per group.
Clinometers	1 per 3 guns, or less, per work.
Vent bit	1 per work.
Extractors, P Special	1 per work.

The Gun Captain will satisfy himself that the buffers are properly connected up, not leaking at the glands, and contain the proper amount of oil. He sees that the capsquares are properly secured, and that the elevating gear is oiled and in working order.

When the breech is opened he looks to see that the bore is clear.

The Gun Layer places the lanyards under his waist-belt. He fixes the sights in the gun, taking care that the foresight fits correctly, and that the deflection leaf of the hindsight works easily. He fixes in position the firing battery and makes the necessary connections, examines the lock and places it in position in the breech screw. He sees that the pointer for traversing arc is let down.

* For proportion allowed for drill and practice, see "Equipment Regulations."

† Special for practice batteries.

2 straps the tube box and Gun Layer's pocket round his waist, places the remainder of his stores in a convenient position on the mounting or emplacement, and sees that the traversing gear is oiled and in working order.

3 removes breech and muzzle covers and fixes elevating wheel.

2 and **3** open the breech as follows:—**3** raises the cam lever to its full extent, then with both hands, gives it a sharp pull towards him hard against the stop and folds it down; **2** then takes hold of the handle of the breech screw with both hands, withdraws the breech screw, and swings it sharply round on its carrier ring.

2 then passes the bit down the vent and examines the breech screw and threads of the breech, sees that they are clean and free from burrs, lubricates the threads with a slight film of oil, and smears the obturating pad with Russian tallow.

To close the breech, **2** swings the breech screw round, **3** raises the cam lever with his right hand, and **2** pushes home the breech screw with both hands on the handle right hand over left and holds it there until **3** locks it by forcing the lever from him as far as it will go; **3** then folds down the lever. **2** must be careful to keep his hands clear of the stop on the carrier ring as the breech screw is turned round.

When the breech is closed **2** inserts a tube, and sees that the guide bolt for lock is home.*

The Gun Layer fires the tube, **2** extracts the tube and rimes out the vent.

4 places the combined rammer and sponge in rear of the gun, head to the front, and resting on the bucket.

5, after assisting the Gun Layer, goes to the shell depôt or recess.

6 goes to the cartridge recess and prepares to issue cartridges. At drill he places the cartridge cases and drill cartridges outside the cartridge recess.

7 goes to the shell depôt or recess, places his stores outside the shell recess, and prepares shell for loading, *i.e.*, cleans and fuzes them if not already done.

Each number will report to the Gun Captain regarding any damage or deficiency.

After each number has completed his work he takes post as follows:—

Gun Captain and Gun Layer in the most convenient positions.

2, on the right of the gun, facing the breech.

3, on the left of the gun, facing the breech.

4, at the head of the rammer.

5, **6** and **7** as above detailed.

To Load.

Gun Group Commander.

Gun Captain.

"A Group.... Load."

"A1.... Load."

2 and **3** open the breech as before detailed; **4** takes the sponge cloth from the bucket and hangs it over the mushroom head; he will not wring it out, but place it on as wet as possible.

2 extracts the old tube and rimes out the vent. **5** brings up the projectile point to the left and places it in the bore after **3** has removed the safety pin and cap or plug.

* Care must be taken to see that the range is clear when using vent sealing tubes with ball.

(5 and 7 will change duties, when required, at the discretion of the Gun Captain.)

4 picks up the combined rammer and sponge, and, assisted by 5, rams the projectile home in one motion; the chamber is then sponged out by giving the sponge two half turns to the left; 5 then quits the stove, 4 withdraws the combined rammer and sponge with a corkscrew motion and replaces it. After the first round the sponge head will be thoroughly soaked in water before loading.

6 brings up cartridge in case, 3 places it in the chamber.

4 now removes the sponge cloth from the mushroom head and puts it back in the bucket, wiping off any loose residue from the previous round.

2 and 3 then close the breech, 2 puts a tube in the vent and sees that the guide bolt for lock is home.

TO LAY AND FIRE.

See General Instructions, Garrison Artillery Training.

The Gun Captain elevates, 2 and 4 traverse; they must be careful not to let go the traversing handle until the gun is fired.

At electric firing, the Gun Layer connects the tube to the firing leads.

If percussion firing is used the Gun Layer hooks one lanyard to the hammer of the percussion lock, and the other to the lanyard bolt.

On receipt of the order "*Commence Firing*," from the Gun Group Commander, the Gun Layer will cock the lock with the cocking lanyard and drop it; after receiving the order "*A1 Fire*" from his Gun Captain, he will fire by pulling the firing lanyard.

AFTER FIRING.

As soon as the gun is fired, the Gun Captain removes the firing plug, if used, and brings the gun into a convenient position for loading. The Gun Layer detaches the lanyards, 2 and 3 open the breech, remainder as before detailed.

TO UNLOAD AT DRILL.

The gun is unloaded by the numbers who loaded it.

FOR ACTION, UNDER COVER, MISSFIRE, CEASE FIRING, REPLACEMENT OF CASUALTIES, DETACHMENT REAR, see Garrison Artillery Training.

The positions under cover are as follows:—

Gun Captain where he can best regain his position for superintending the working of the gun.

2 and 4 on the right of the gun.

3 and the Gun Layer on the left of the gun.

5 and 7 by the shell recess.

6 by the cartridge recess.

All sitting or kneeling.

TO CEASE FIRING AND REPLACE STORES.

The gun is depressed and all stores replaced by the numbers who brought them up.

The detachment then falls in at "*Detachment Rear*."

INSTRUCTIONS FOR USING THE LARGE CLINOMETER.

To read the angles marked on the drum.—The brass drum is marked in degrees, commencing at 0° on the top to 45° at the bottom. Each degree is subdivided into twelve parts; each small division therefore represents an angle of five minutes.

The scale is read from right to left, thus:—



the reading opposite the arrow would indicate an angle of $2^\circ 25'$.

To lay a gun at any angle up to 45° .—Unscrew the drum until the \uparrow points to the elevation required. Place the clinometer thus—

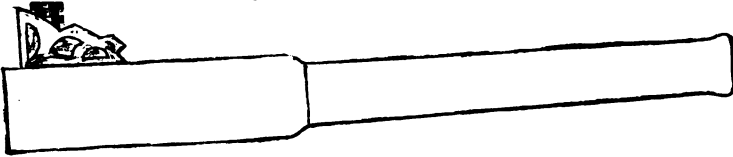

on the plane surface cut on the breech, or against the muzzle, thus—

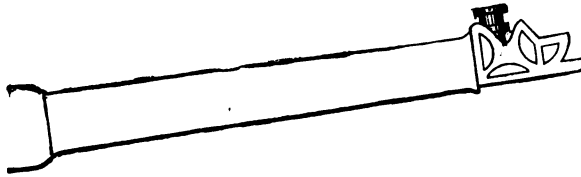

and elevate the piece until the bubble of the spirit level is in the centre of the tube.

For angles of depression.—Proceed as above, but reverse the direction of the instrument, placing it thus on the breech of the gun—

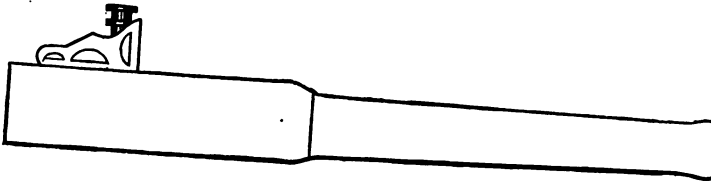

Preservation and Adjustment of the Instrument.—In order to preserve the clinometer in efficient working order it is necessary to keep the working parts free from grit and dust as far as possible. As excess of oil is apt to cause the adhesion of grit, only sufficient is to be applied to make the screw work smoothly, and to keep the steel parts from rusting.

On no account should the instrument be taken to pieces, as it requires special tools to put it together again.

(5506)

D

Instruments are issued in correct adjustment, and with due care will remain correct for many years.

To ascertain if the instrument is in adjustment :—

- (a) Carefully clean the plane surface cut on a gun for use with the clinometer.
- (b) Turn the drum to zero.
- (c) Place the instrument on the plane surface (drum towards breech), and elevate or depress the gun till the bubble is in the centre of its run.
- (d) Turn the clinometer end for end.
- (e) Should the bubble not return to the centre, the instrument is out of adjustment.
- (f) As the amount of the error will generally be small it is advisable to add or subtract the error, as the case may be, rather than correct the adjustment.
- (g) To ascertain the error after complying with (d) (drum towards muzzle), turn the drum until the bubble is again in the centre of its run ; *one half* the reading on the drum is the index error.
- (h) If the reading falls on the *black* markings on the drum *add half* the amount when setting the clinometer for any required *elevation*.
- (i) If the reading falls on the *red* markings on the drum *subtract half* for any required *elevation*.

If it is required to adjust the clinometer to have *no* index error, set the drum to the ascertained index error (keeping the drum end towards muzzle), and bring the bubble to the centre of its run by manipulating the capstan-headed nuts (using a tempered steel wire just fitting the holes in the nuts). Then placing the drum at zero, elevate or depress the gun till the bubble is in the centre.

Reversing the instrument end for end should not alter the central position of the bubble ; should it do so, proceed as before until there is no change.

BOX.

4-IN. B.L. TRAVELLING

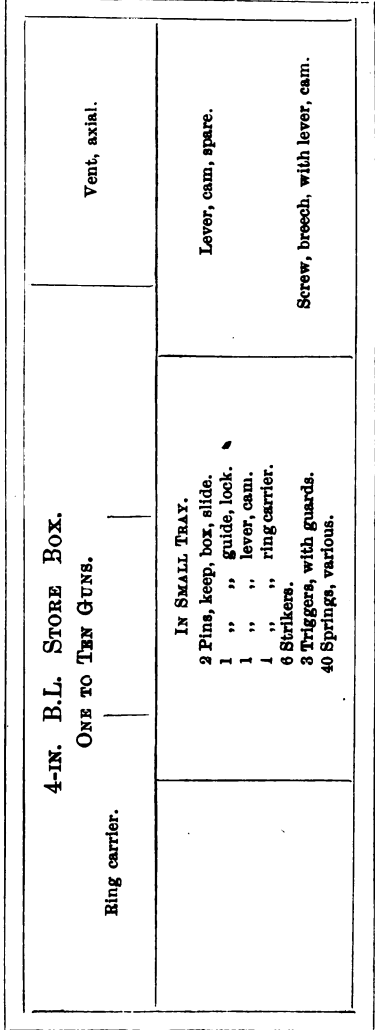
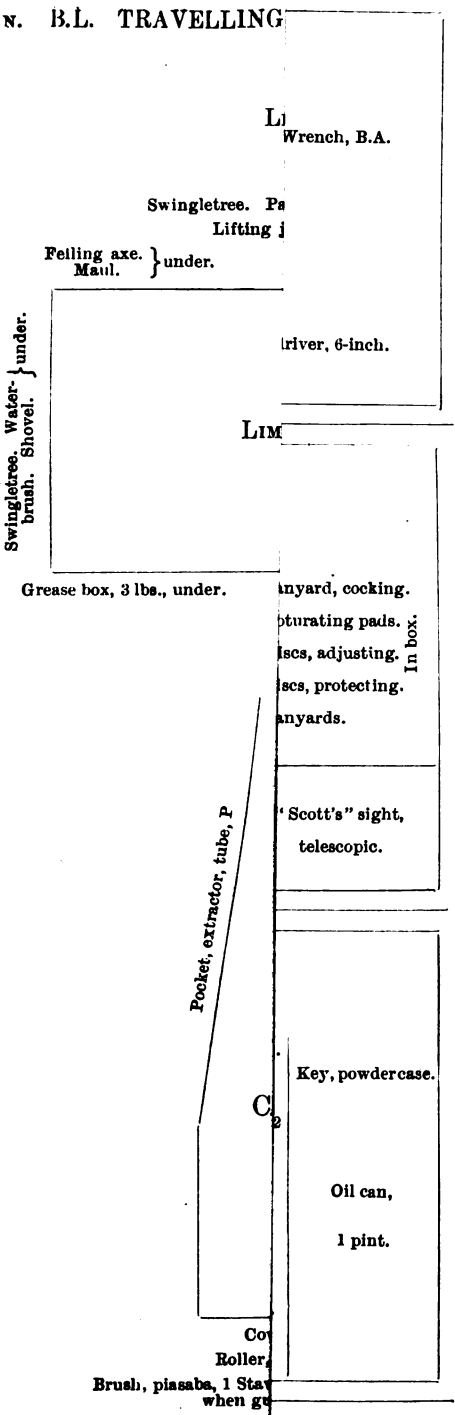

(5506)

ALTERATIONS.

Para. of List of Changes.	Nature of Change.	Remarks.

Para. of List of Changes.	Nature of Change.	Remarks.

Para. of List of Changes.	Nature of Change.	Remarks.

Para. of List of Changes.	Nature of Change.	Remarks.

(Wt. 13075 3,000 9 | 04—H & S 5506)

ORDNANCE, B. L., 4-INCH, MARK V.

STEEL; 26 - CWT.

Scale $\frac{1}{16}$.

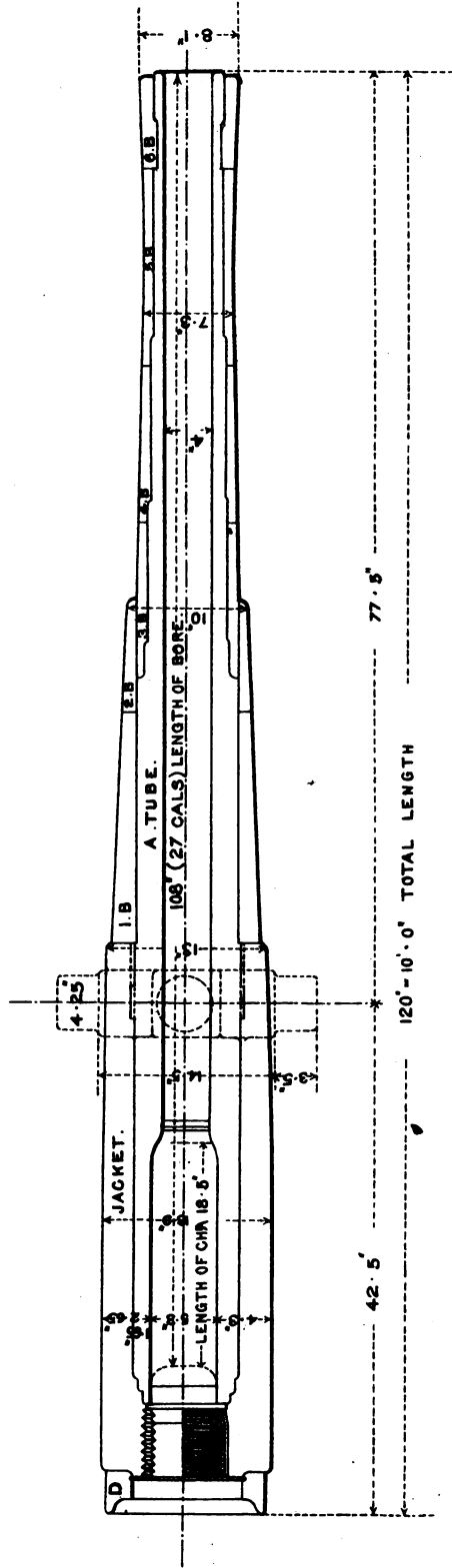

N° OF GROOVES

24.



SECTION OF RIFLING.
FULL SIZE.

ORDNANCE, B. L., 4-INCH. MARK. VI.

STEEL 126-CWT.

Scale $\frac{1}{10}$.

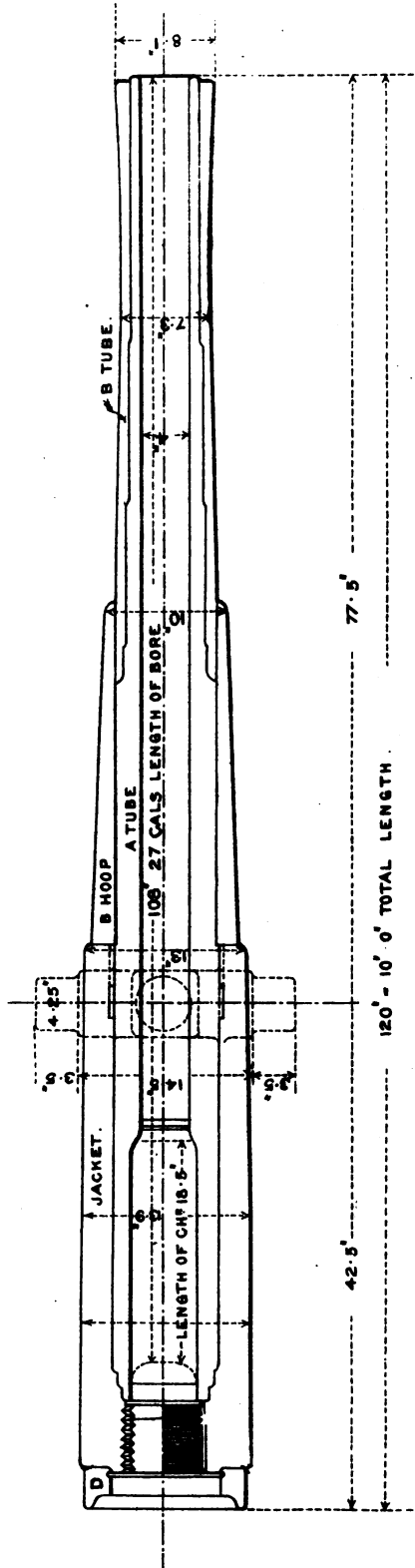

Nº OF GROOVES
24.

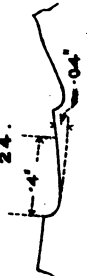

SECTION OF RIFLING.
FULL SIZE.

ORDNANCE, B. L., 4 INCH, MARKS V & VI.
BREECH CLOSING MECHANISM

Scale 1/4"

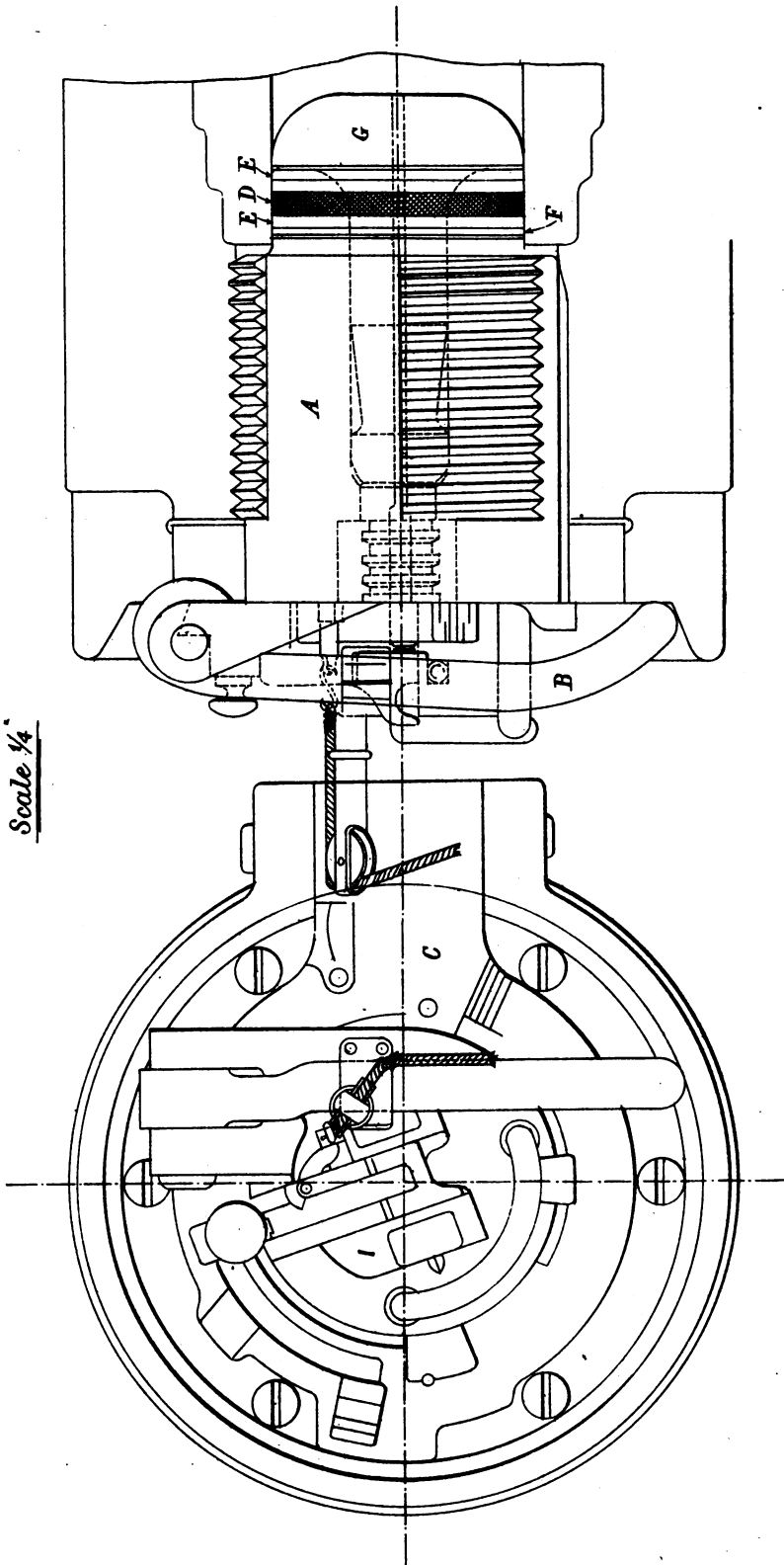

**ORDNANCE, B. L., 4-INCH, MARKS V & VI.
PERCUSSION LOCK.**

SCALE 1/2.

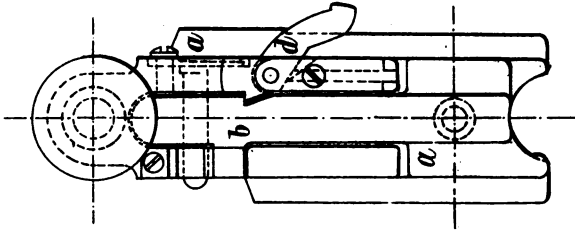
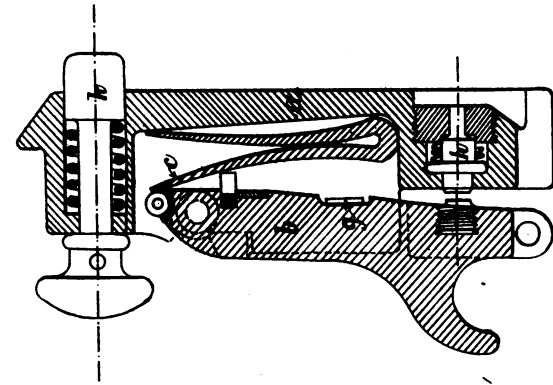

**ORDNANCE, B. L., 4-INCH, MARKS V & VI.
BRACKET, TELESCOPIC SIGHT, STEEL.**

SCALE 1/2.

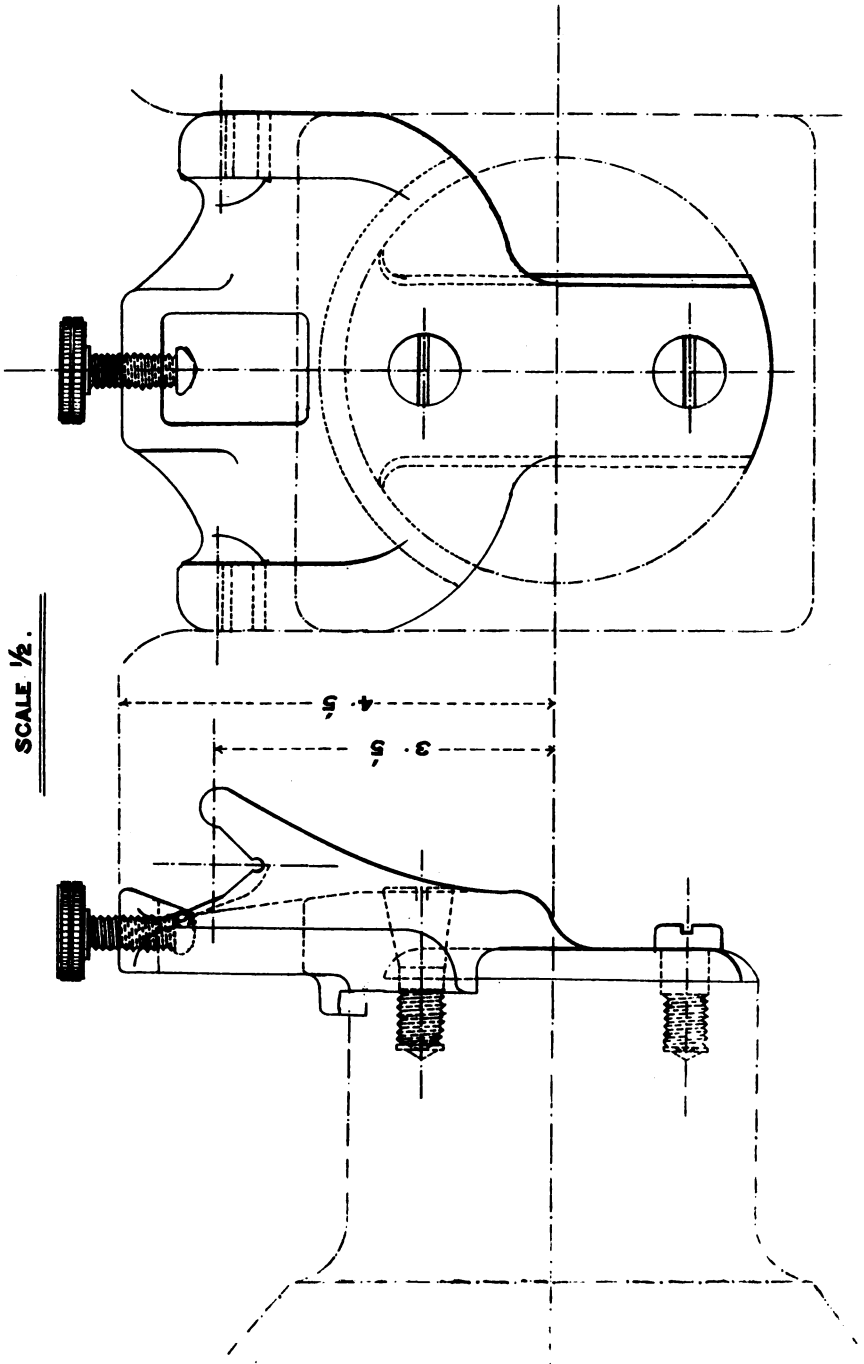

BOX, OBTURATING PADS AND DISCS B.L. 4 INCH MARK II
1/3 SCALE

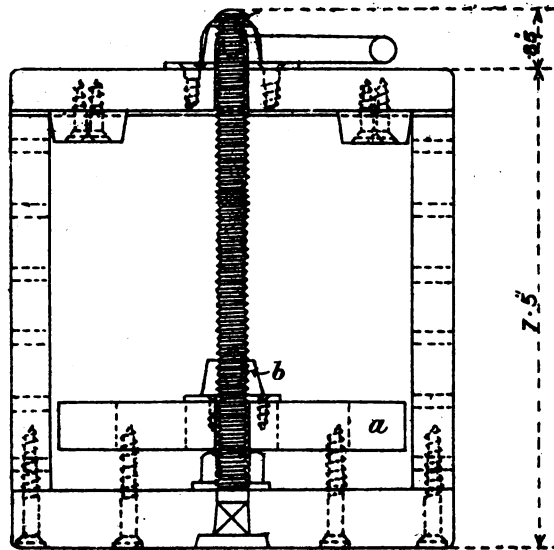

SECTION AT A.B.

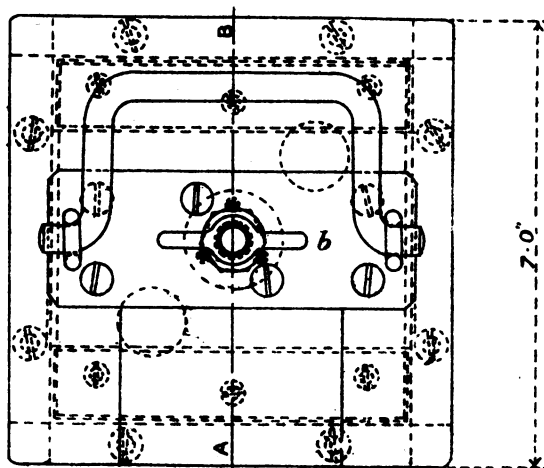

PLAN

EXTRACTOR, TUBE, P. (MARK I)

STEEL, VENT SEALING, PERCUSSION.

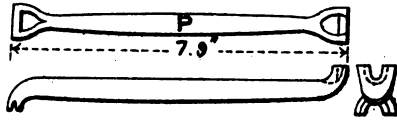

EXTRACTOR, TUBE, P. SPECIAL (MARK I.)

STEEL, VENT SEALING, PERCUSSION.

SCALE $\frac{1}{4}$.

SECTION THRO A. B.

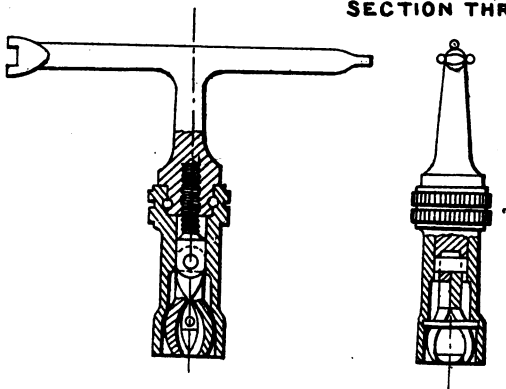

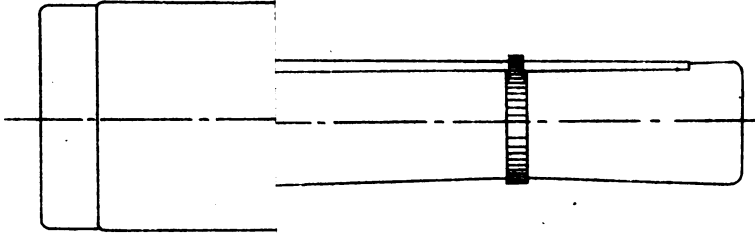

UN.

CARRIAGE, TRAVELLING, B. L., 4-INCH, 6 FT. PARAPET, MARK I.

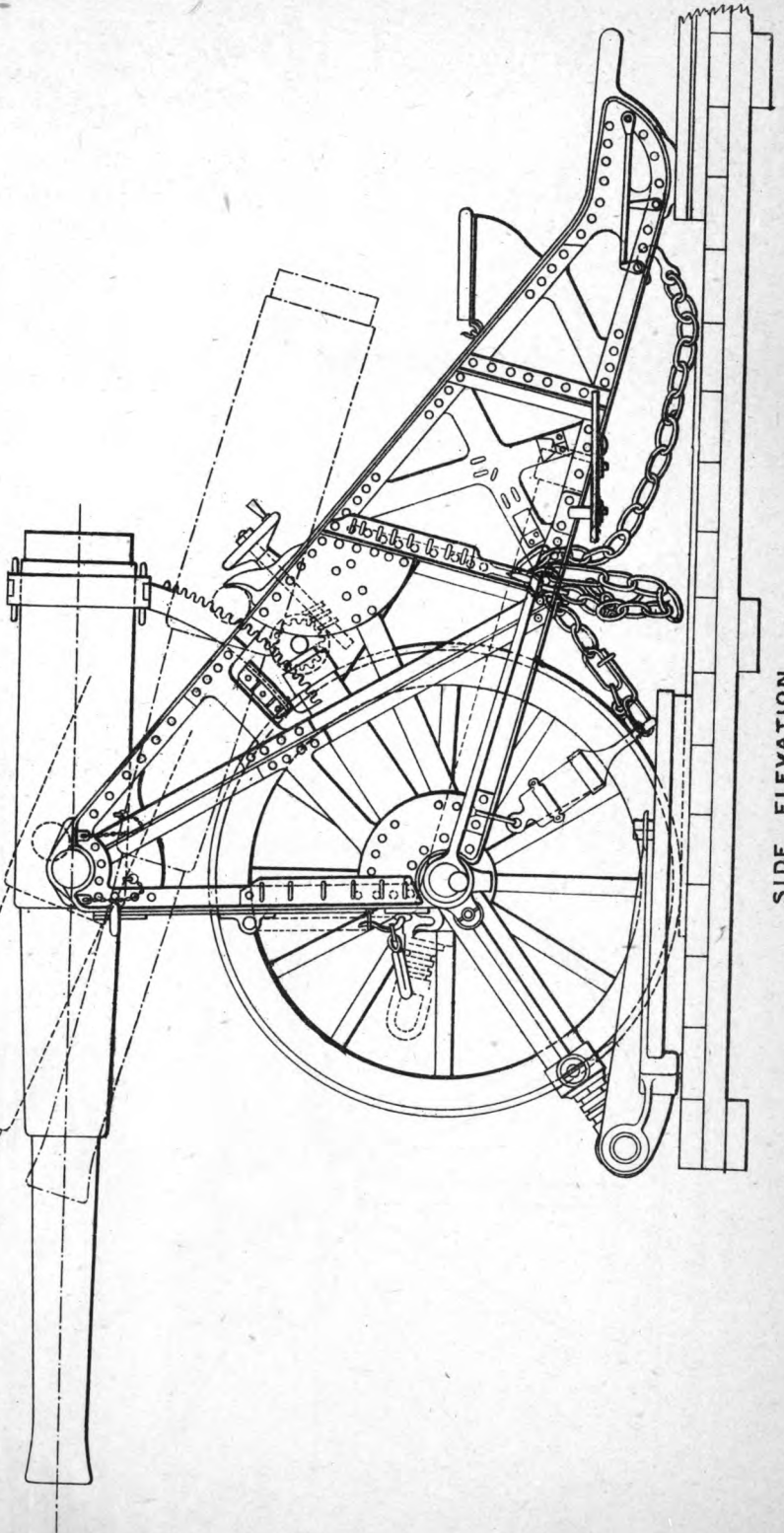

SIDE ELEVATION

LIMBER, SIEGE:

IRON, WITH GREASE BOX.

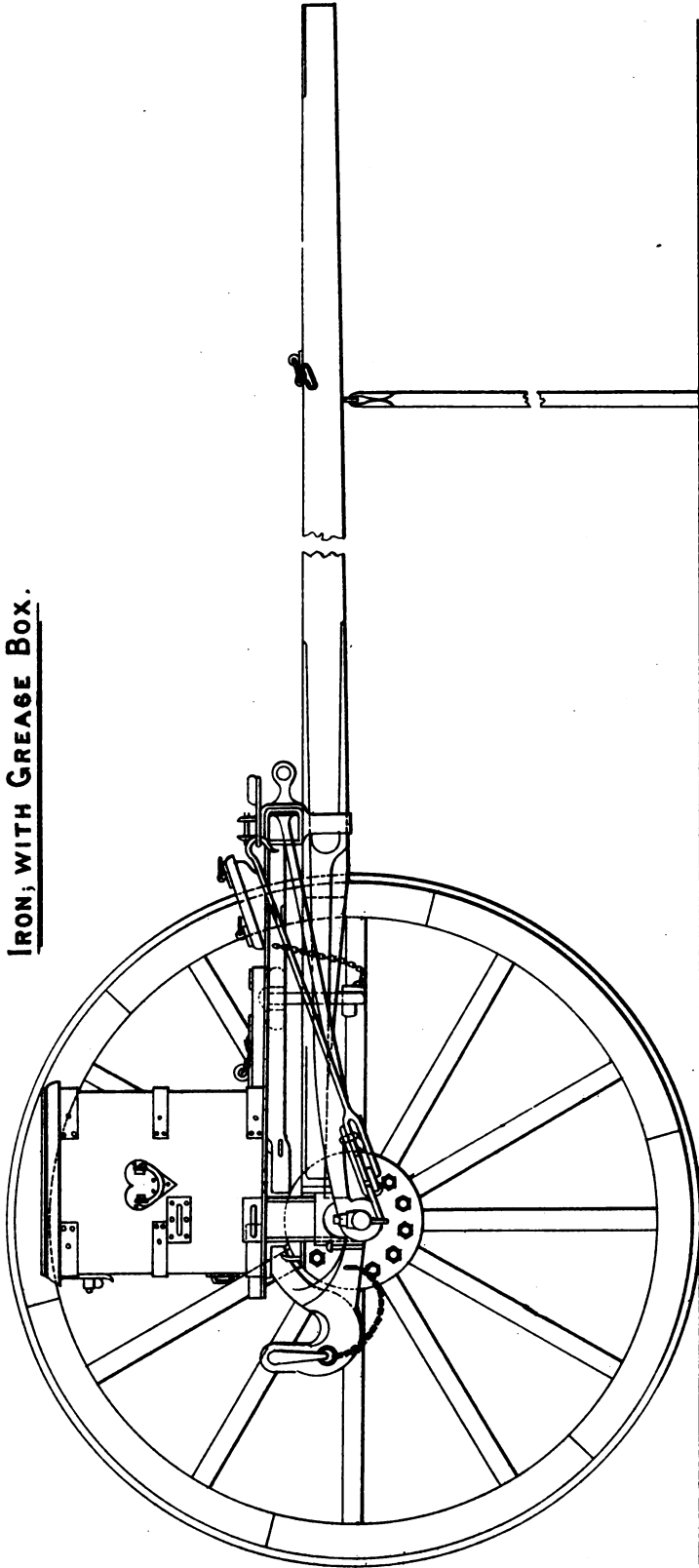

Note: This is the same Limber as used with R. M. L. Howitzer Carriages, but when issued for 4' and 5' B. L., Travelling Carriages, it is fitted with a box special to these services.

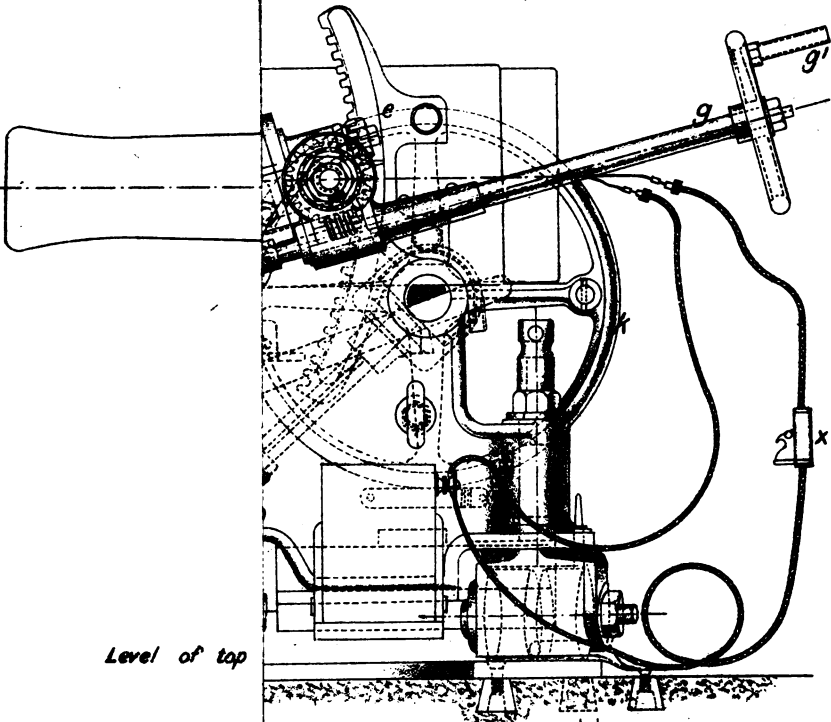

Level of top

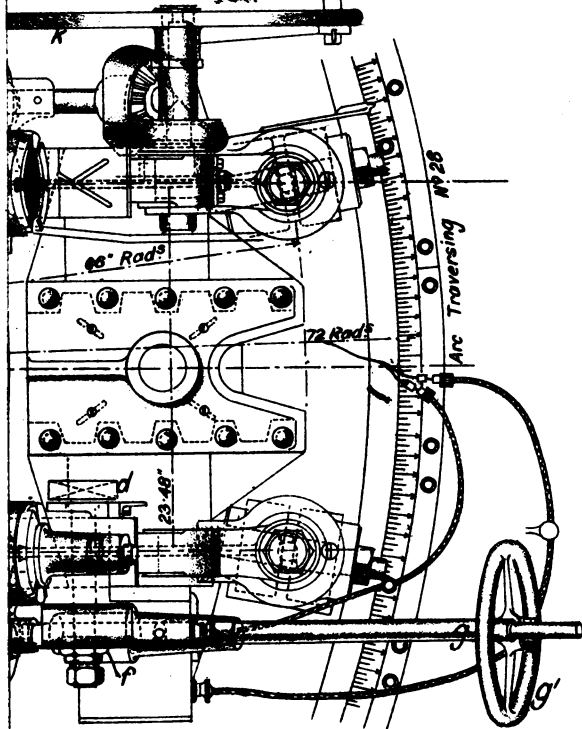

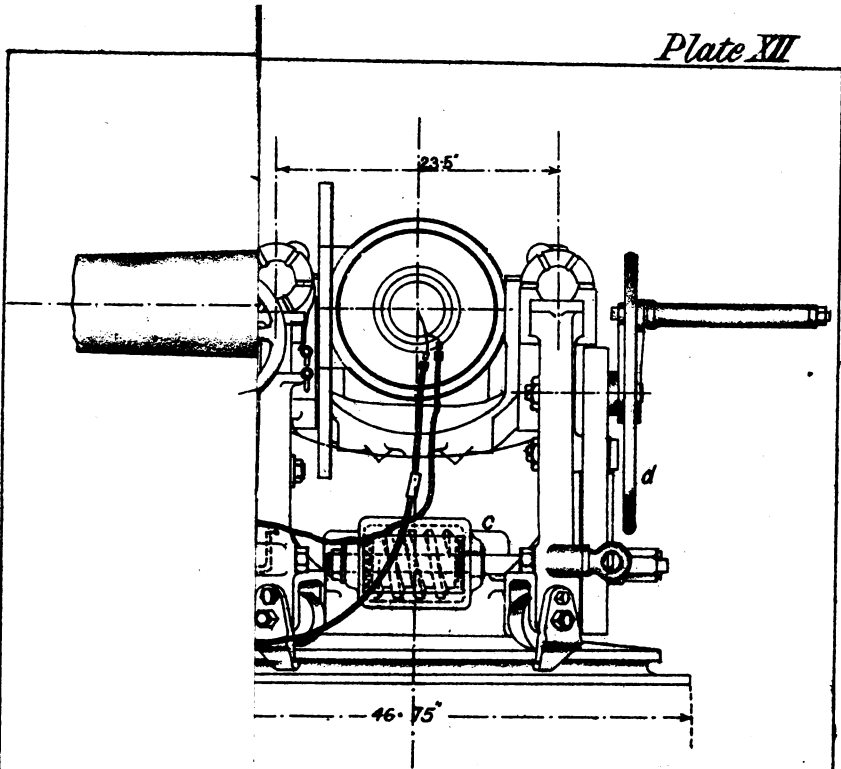

B.L. 4 INCH, VASSEUR, MARK II L.

ROM NAVAL C.P. MARK I

Scale $\frac{1}{16}$

PLATFORM, SIEGE, DOUBLE-DECKED, "C" PIVOT, MARK I.

WOOD, GROUND FOR B. L. SIEGE GUN.



ELEVATION.

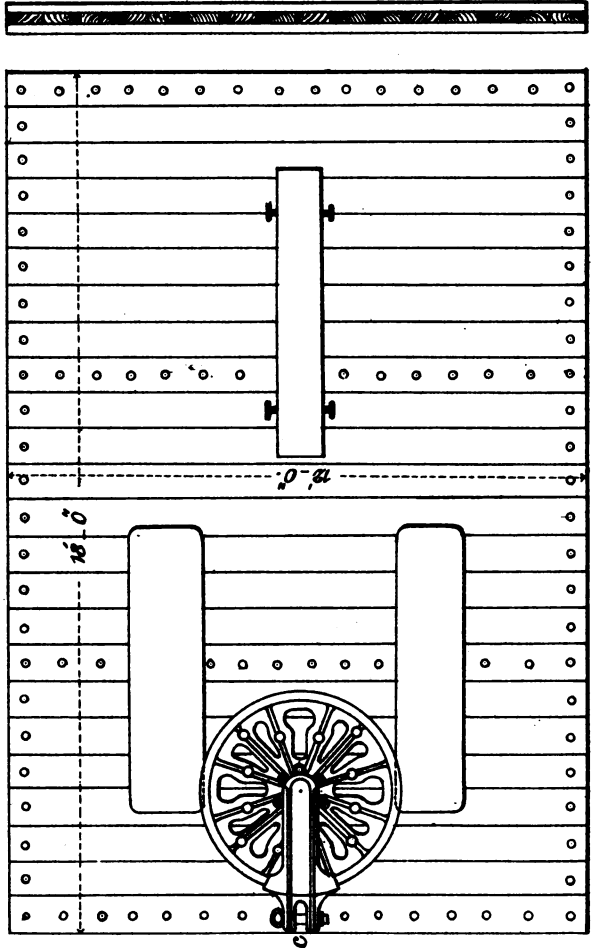

END VIEW.

TOP PLAN.

PLATFORM, SIEGE, DOUBLE - DECKED, "C" PIVOT, MARK II.

SCALE 1/36.

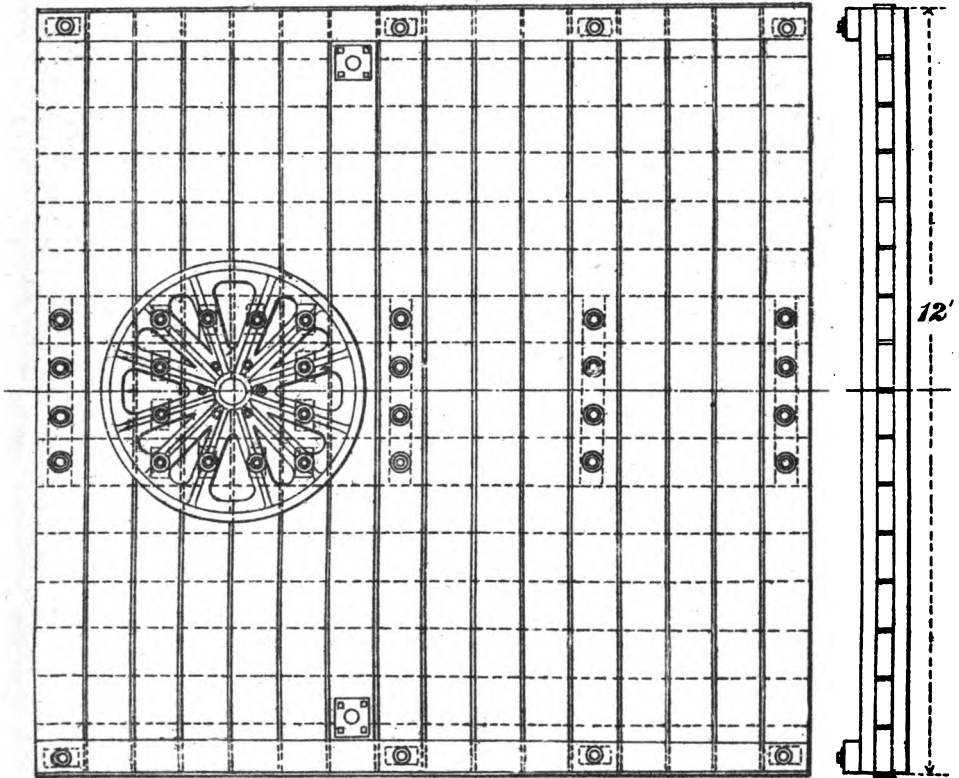

PLAN.

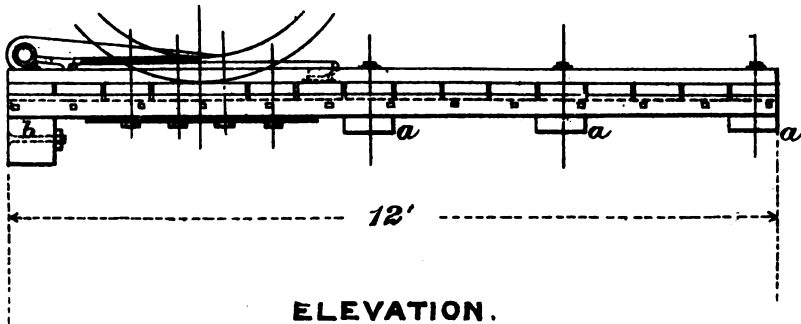

ELEVATION.

UNIVERSITY OF MICHIGAN

CARTRIDGES, B. L., 4 INCH.

SCALE $\frac{1}{4}$.

CARTRIDGE, B. L., 4-INCH, 12 LB., SP., MARK I.
(SILK - CLOTH.)

CARTRIDGE, DRILL,
B. L., 4-INCH, 12-LB. MARK I.
(RAW-HIDE)

CARTRIDGE, B. L., 4 INCH, 4 LB., MARK I.
SALUTING. (SILK-CLOTH.)
BLANK. L. G.

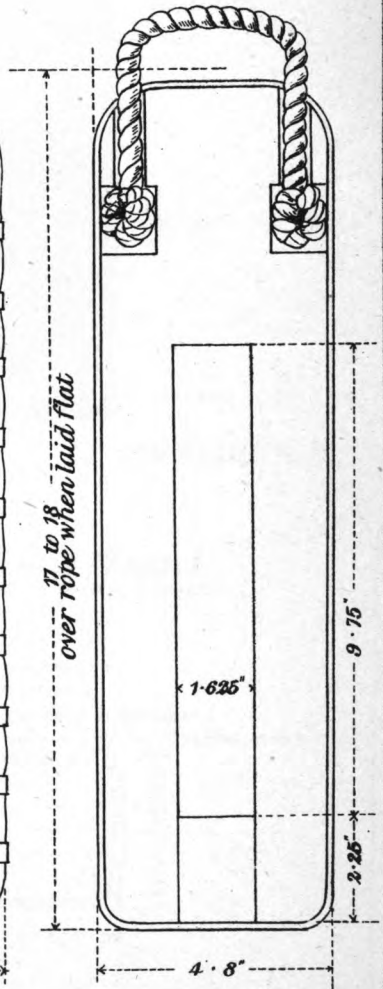
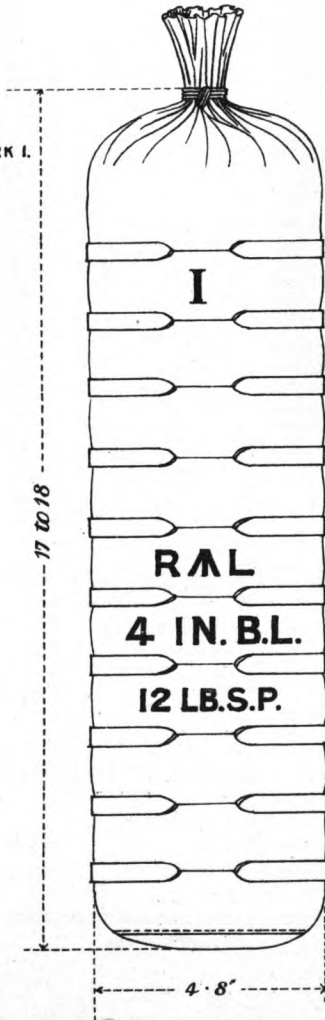
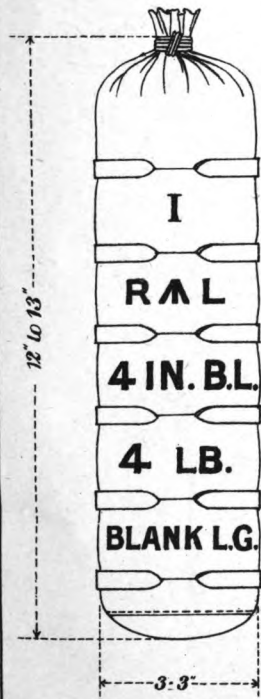

CARTRIDGE, B.L., 4-INCH, 3-LB 1 OZ. CORDITE SIZE 5, MARK I.

SILK-CLOTH.

Scale 1/4

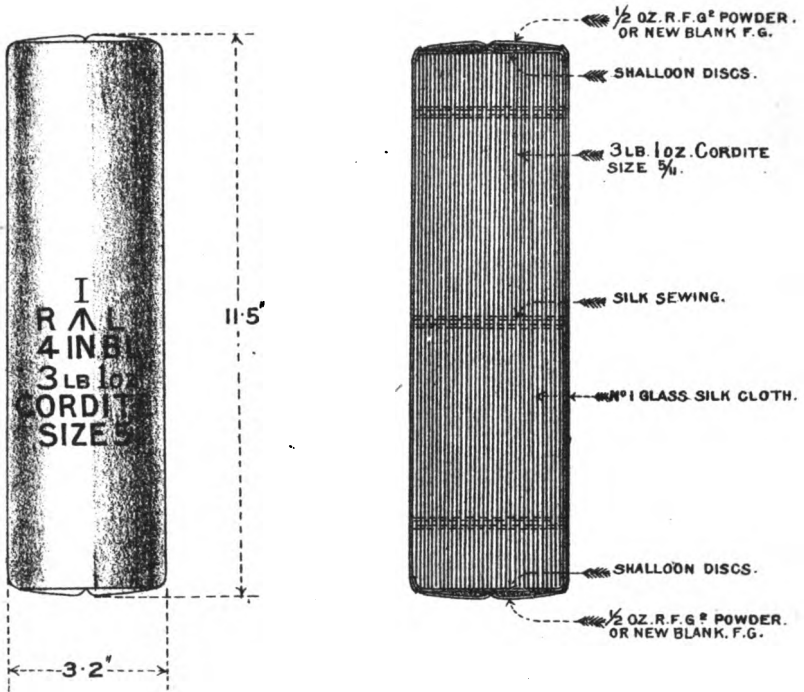

CARTRIDGE, B.L. DRILL, 4 INCH, 3 LB. 1 OZ., MARK I.

RAW HIDE.

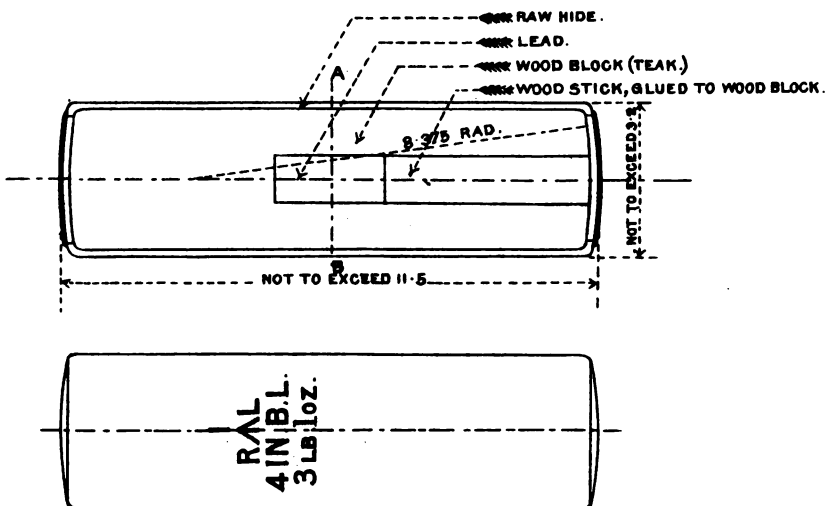

PROJECTILES, B. L., 4-INCH.

SCALE $\frac{1}{4}$

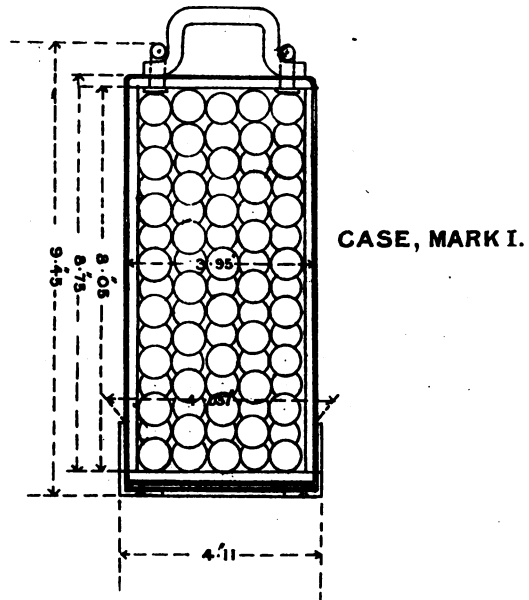
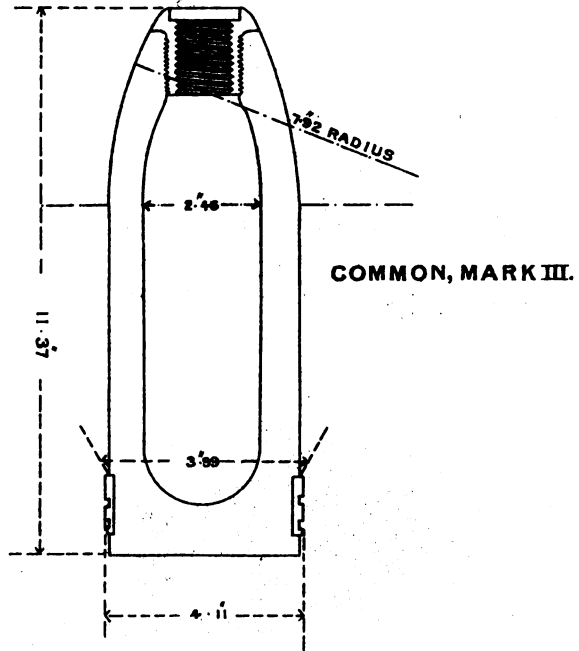

SHELL, B.L., Q.F. OR Q.F.C., COMMON, 4 INCH, FORGED STEEL, MARK V.

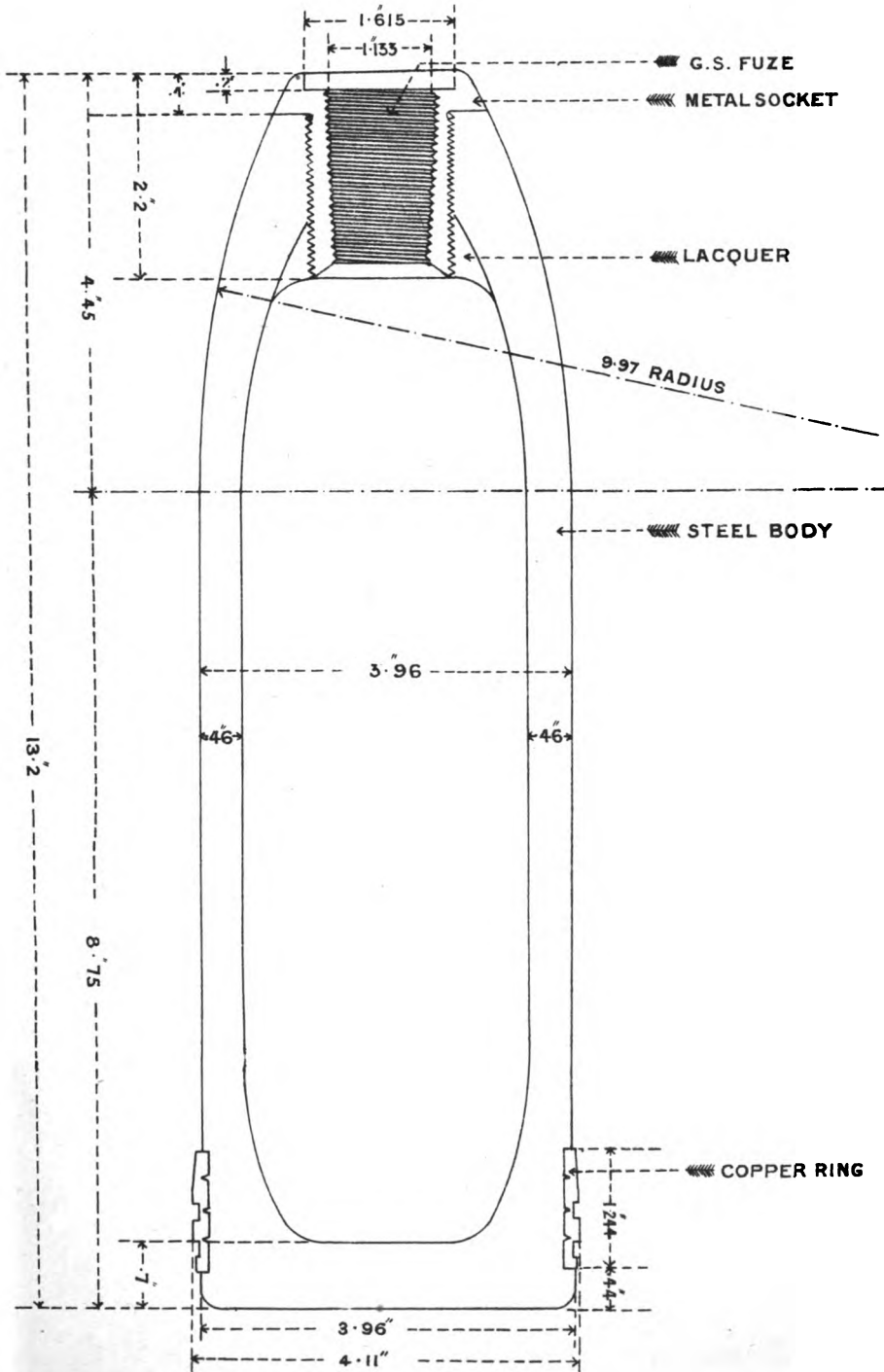

SHELL, B.L. Q.F. OR Q.F.C. SHRAPNEL, 4-INCH, FORGED STEEL, MARK V.

SCALE 1/2.

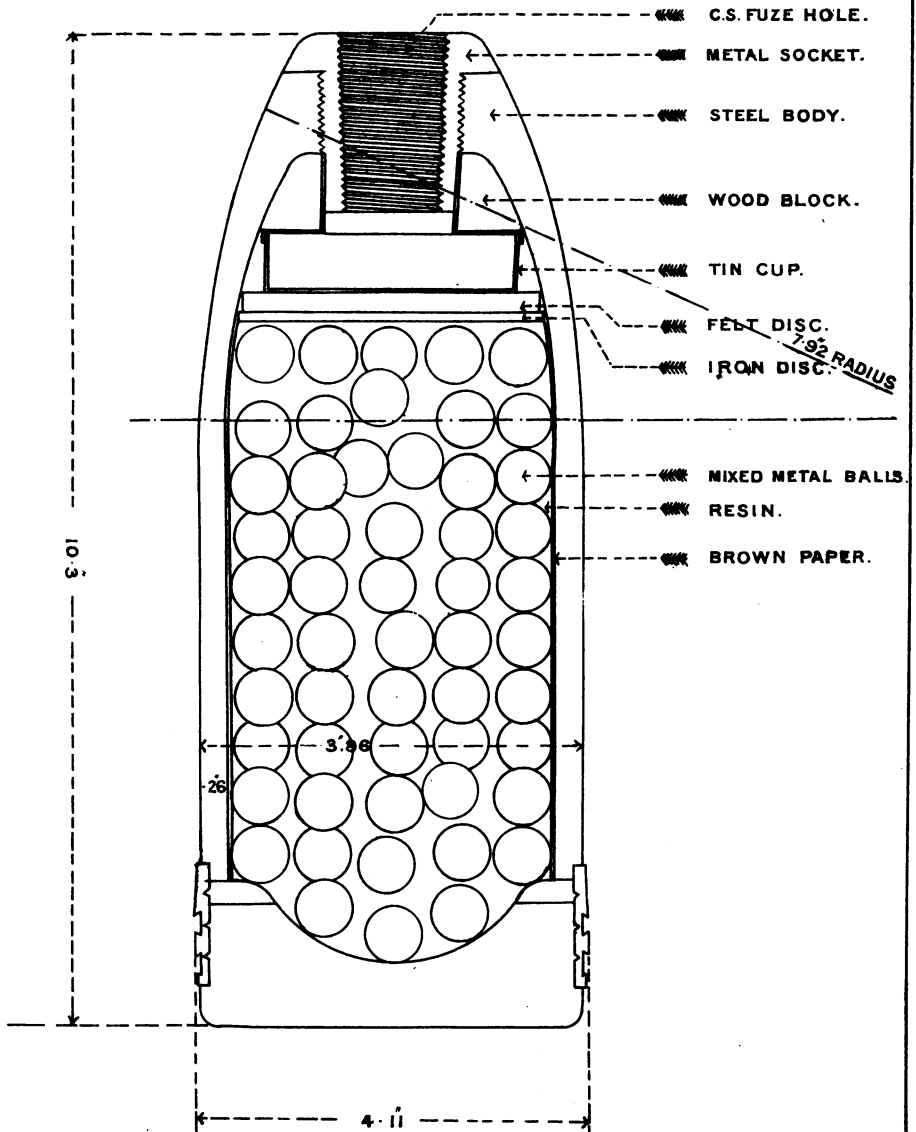

SHELL B.L., Q.F. OR Q.F.C., SHRAPNEL 4 INCH MARK VIII

FORGED STEEL

Scale $\frac{1}{2}$

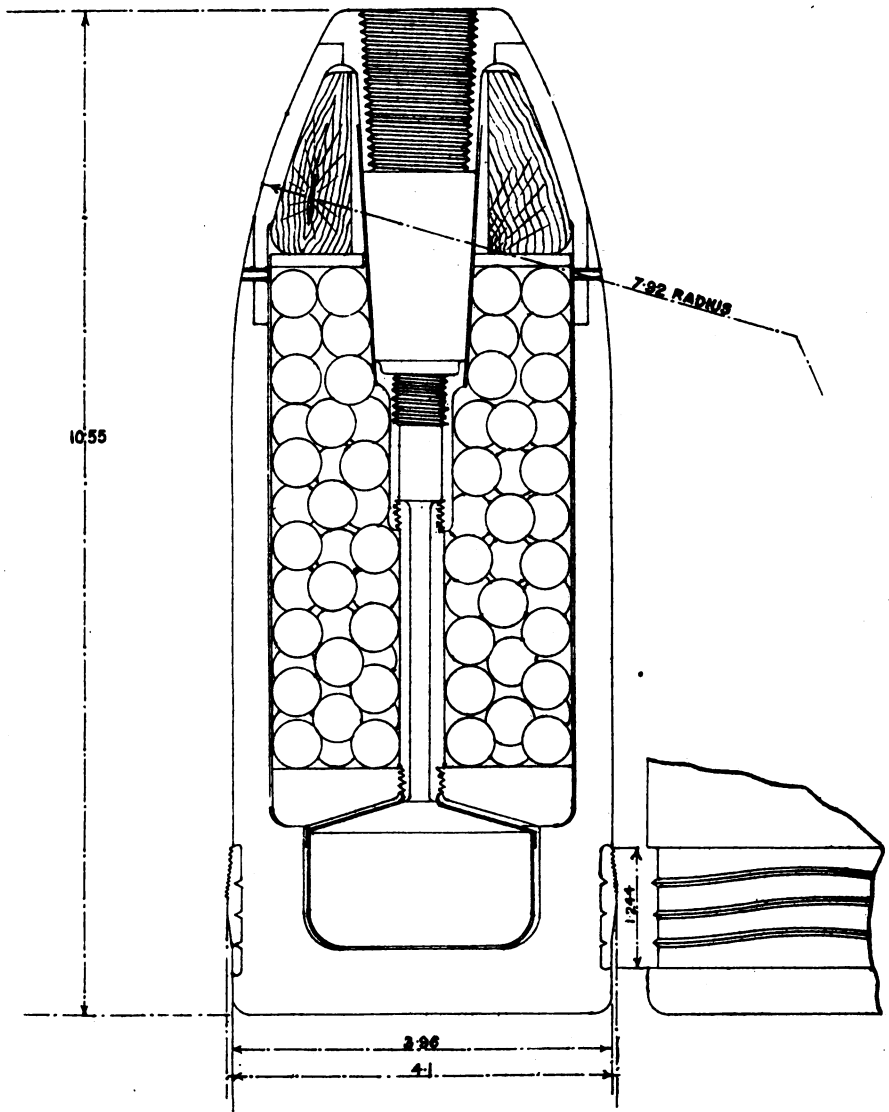

188/12 02

Weller & Graham, Ltd. Litho. London.

FUZE, PERCUSSION, SMALL, N° 8, MARK IV.

FULL SIZE.

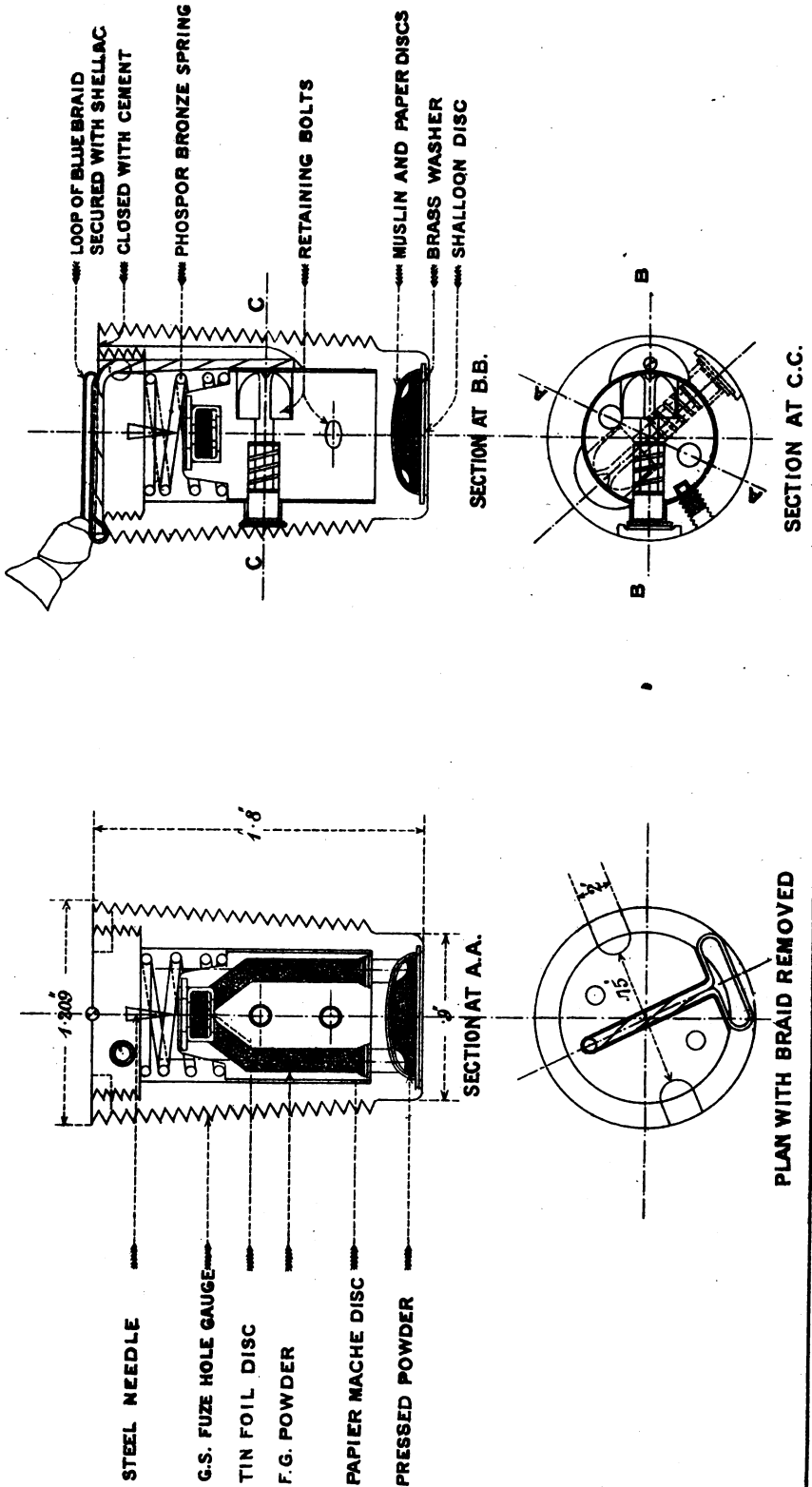

FUZE, TIME AND PERCUSSION, SHORT, N° 55, MARK III.

Full Size.

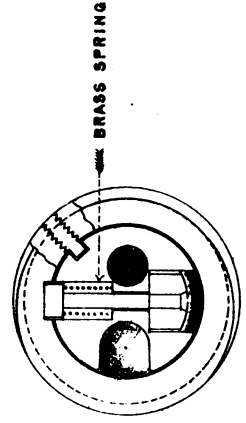
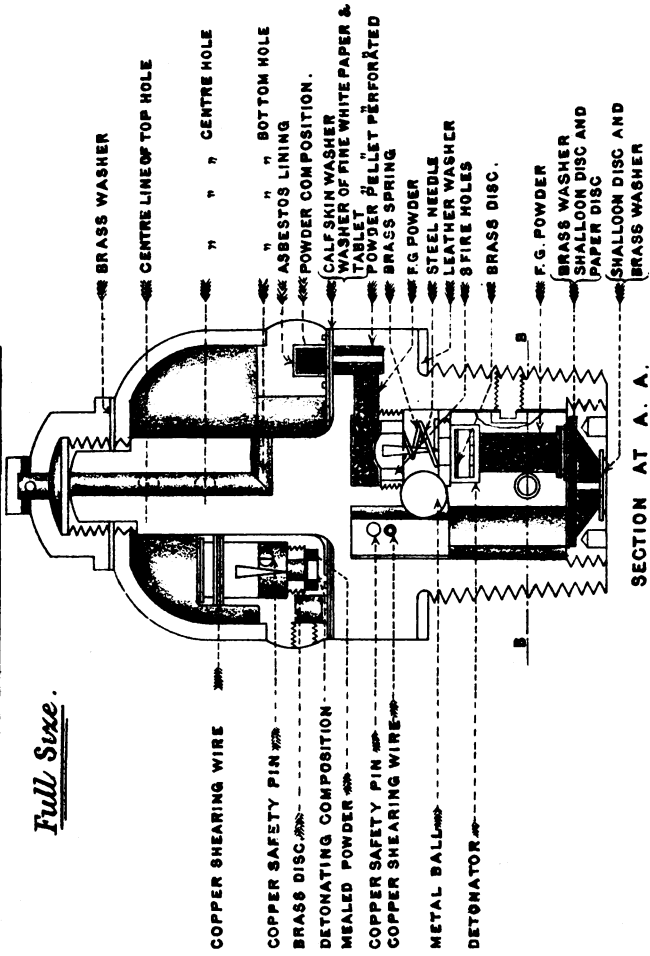
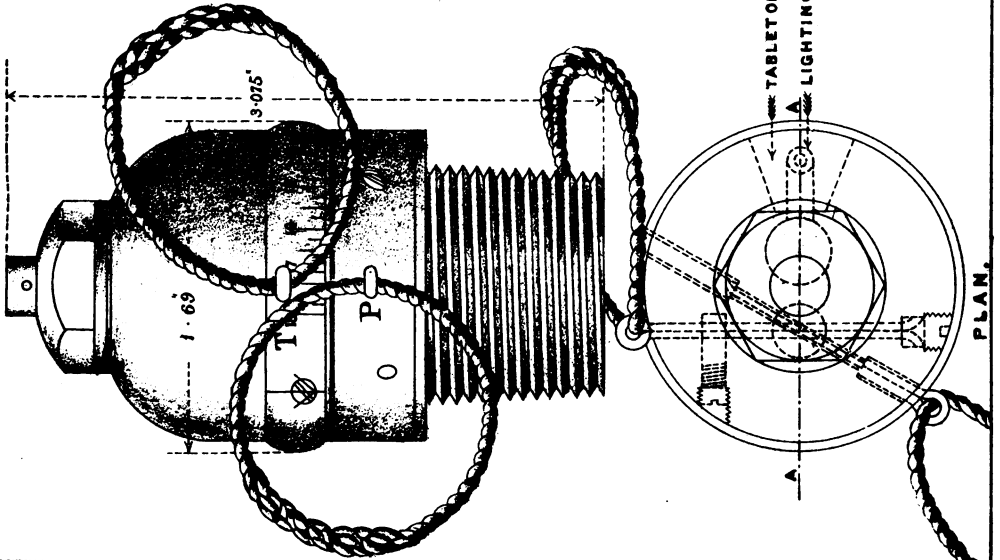

- BRASS WASHER
- CENTRE LINE OF TOP HOLE
- CENTRE HOLE
- BOTTOM HOLE
- ASBESTOS LINING
- POWDER COMPOSITION.
- CALESKIN WASHER
- WASHER OF FINE WHITE PAPER & TABLET
- POWDER PELLET PERFORATED
- BRASS SPRING
- F.G. POWDER
- STEEL NEEDLE
- LEATHER WASHER
- 9 FINE HOLES
- BRASS DISC.
- F.G. POWDER
- BRASS WASHER
- SHALLOON DISC AND PAPER DISC
- SHALLOON DISC AND BRASS WASHER
- BRASS SPRING
- SECTION AT A. A.
- SECTION AT B. B.
- BRASS SPRING
- TABLET OF FINE WHITE PAPER.
- LIGHTING POINT.
- PLAN.
- 1.69
- 3.075
- COPPER SHEARING WIRE
- COPPER SAFETY PIN
- BRASS DISC
- DETONATING COMPOSITION
- MEALD POWDER
- COPPER SAFETY PIN
- COPPER SHEARING WIRE
- METAL BALL
- DETONATOR

FUZE, TIME AND PERCUSSION, N° 56-MARK IV.

Full Size.

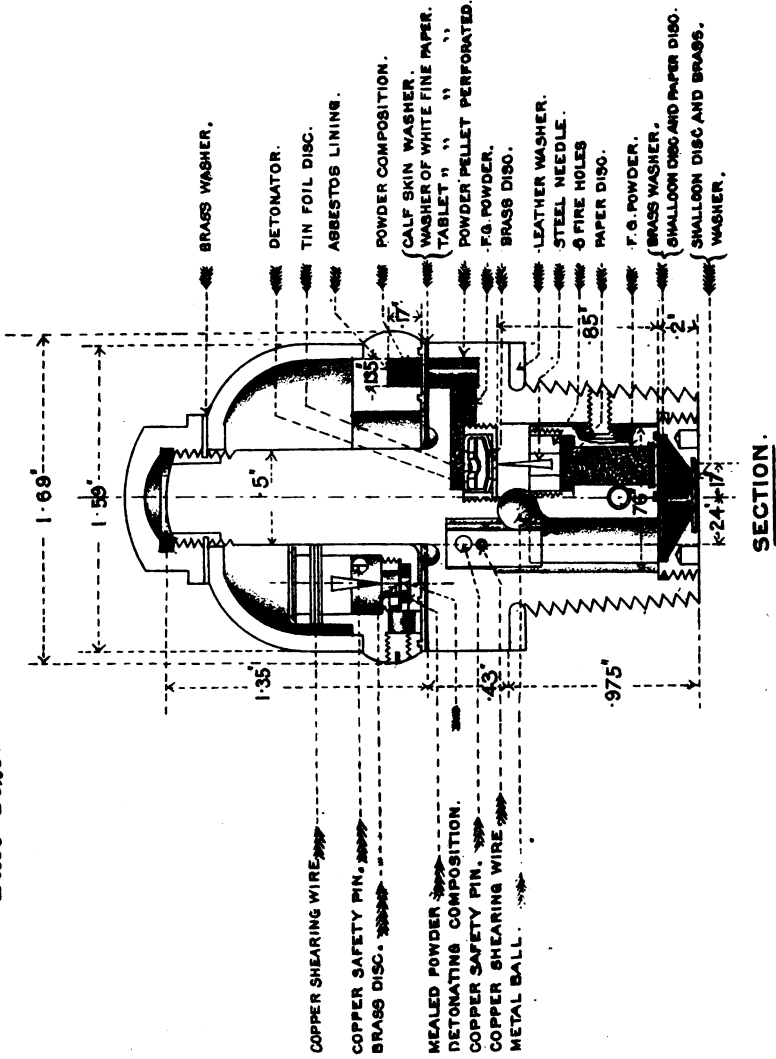

SECTION.

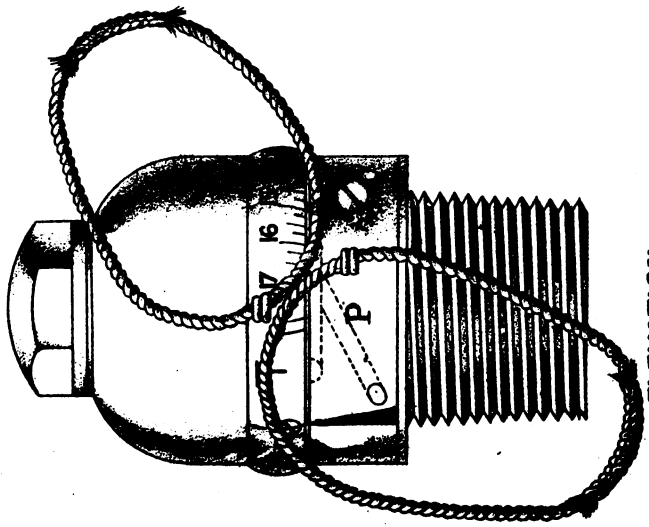

ELEVATION.

TUBE, VENT-SEALING, ELECTRIC. P., MARK VII.

BRASS

FULL SIZE.

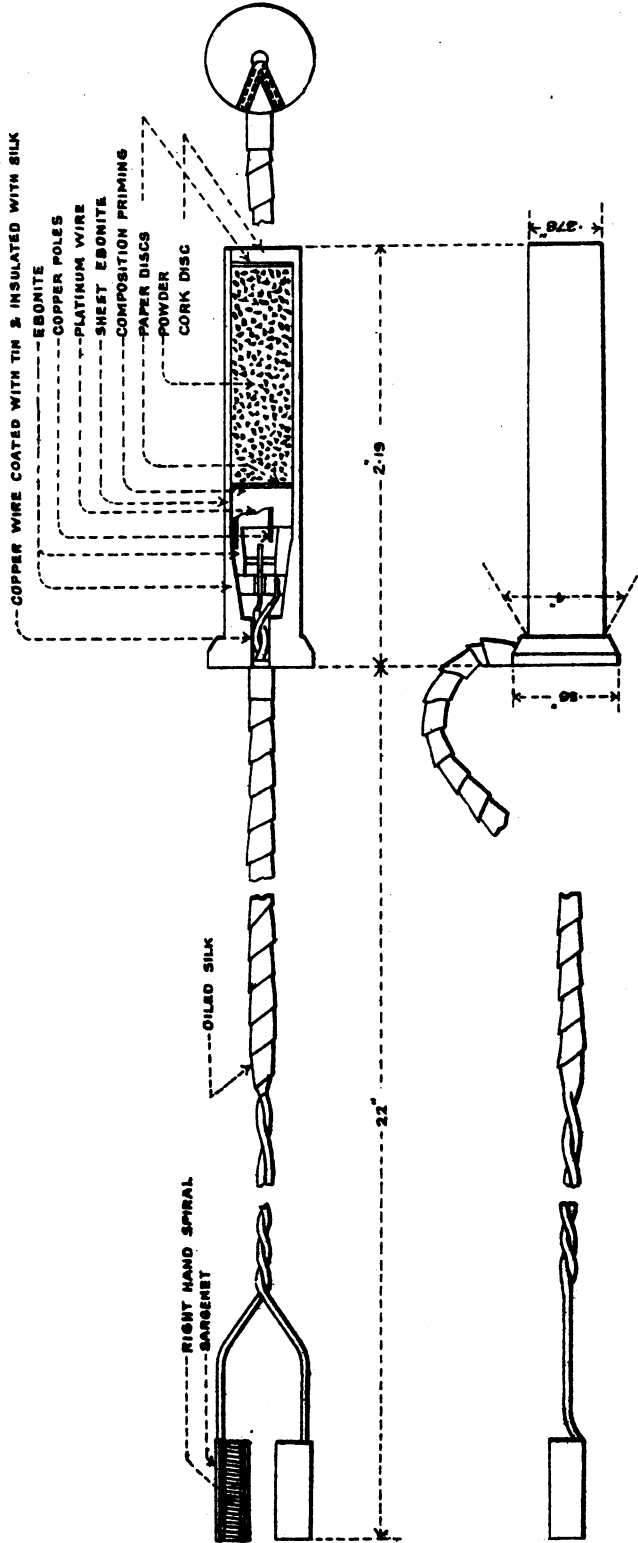

TUBE, VENT-SEAL, PERCUSSION. MARK III.

BRASS
FULL SIZE

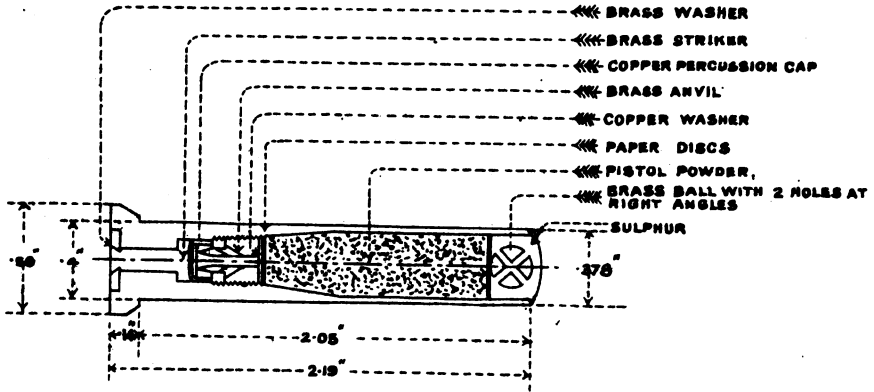

TUBE, VENT-SEALING, PERCUSSION, MARK IV.

BRASS

FULL SIZE

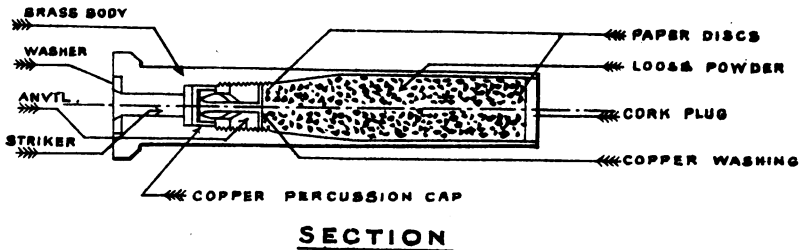
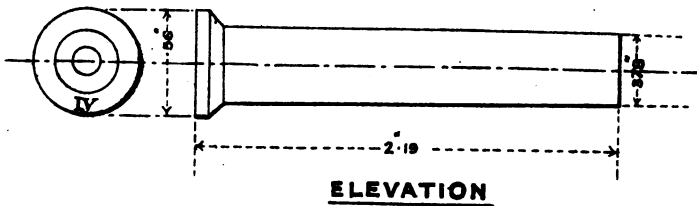

TUBE, VENT SEALING, PERCUSSION. (M⁶ VI).

FULL SIZE.

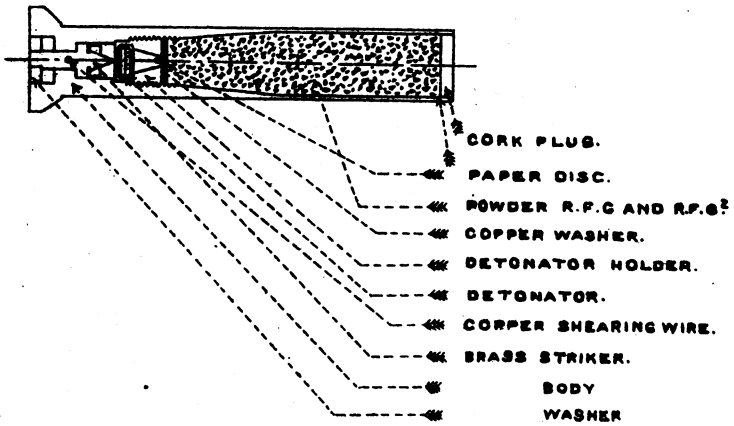
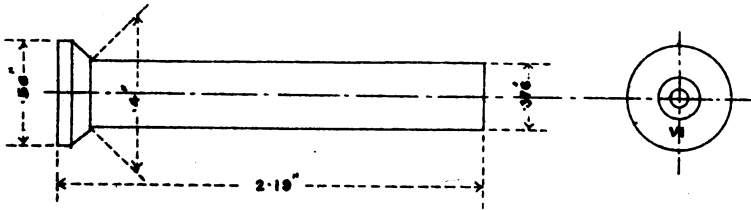

TUBE, VENT SEALING, PERCUSSION. (M⁶ VII) | C |.

FULL SIZE.

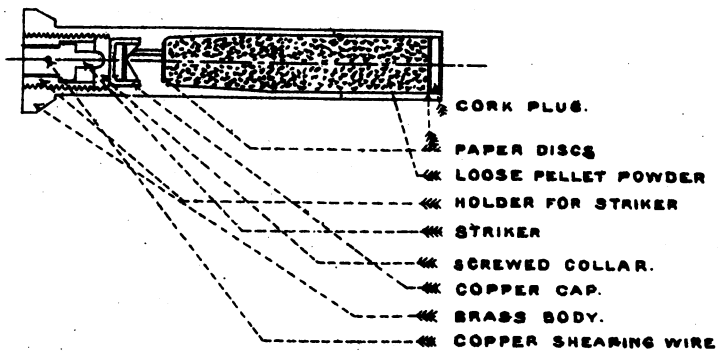
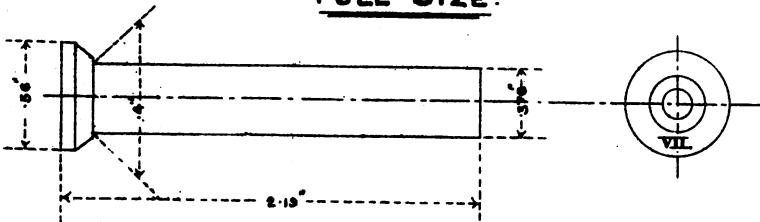

THE UNIVERSITY OF CHICAGO

PHILOSOPHY DEPARTMENT

PHILOSOPHY 101

LECTURE NOTES

BY [Name]

DATE

CHAPTER 1

INTRODUCTION

THE HISTORY OF PHILOSOPHY

TUBE, VENT-SEALING, ELECTRIC P. DRILL MARK III.

GUNMETAL

FULL SIZE

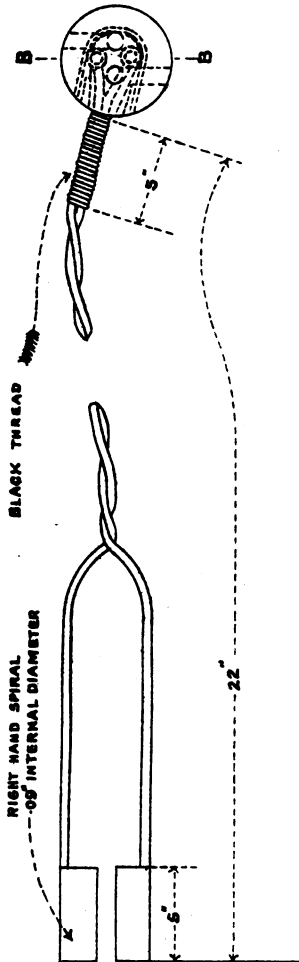

END ELEVATION

- ← COPPER WIRE COATED ALL OVER WITH PURE TIN INSULATED WITH SILK AND TWISTED
- ← GUNMETAL
- ← EBONITE CYLINDER INSIDE DIAM. 7
- ← COMPOSITION PRIMING
- ← PLATINUM SILVER WIRE (.27 GRAIN PER YARD)



SECTION AT A.A.

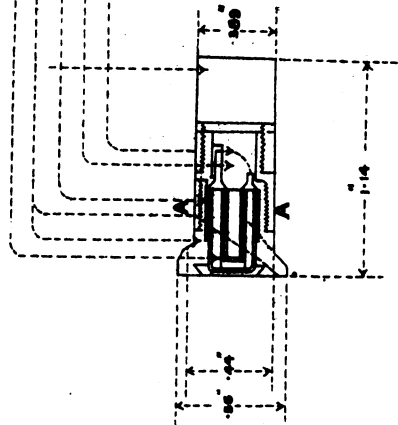

SECTION AT B.B.

TUBES, VENT-SEALING, PERCUSSION, DRILL, MARK I.

GUNMETAL

FULL SIZE

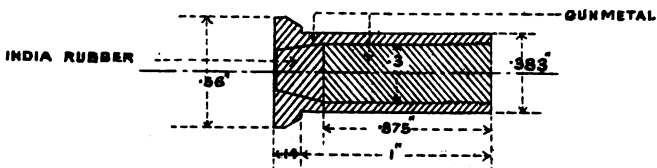

UNIVERSITY OF MICHIGAN



3 9015 02807 5888

